

Non-Gaussian statistics, classical field theory, and realizable Langevin models

John A. Krommes

Plasma Physics Laboratory, Princeton University, P.O. Box 451, Princeton, New Jersey 08543

(Received 5 October 1995)

The direct-interaction approximation (DIA) to the fourth-order statistic $Z \sim \langle (\lambda \psi^2)^2 \rangle$, where λ is a specified operator and ψ is a random field, is discussed from several points of view distinct from that of Chen *et al.* [Phys. Fluids A **1**, 1844 (1989)]. It is shown that the formula for Z_{DIA} already appeared in the seminal work of Martin, Siggia, and Rose [Phys. Rev. A **8**, 423 (1973)] on the functional approach to classical statistical dynamics. It does not follow from the original generalized Langevin equation (GLE) of Leith [J. Atmos. Sci. **28**, 145 (1971)] and Kraichnan [J. Fluid Mech. **41**, 189 (1970)] (frequently described as an amplitude representation for the DIA), in which the random forcing is realized by a particular superposition of products of random variables. The relationship of that GLE to renormalized field theories with non-Gaussian corrections (“spurious vertices”) is described. It is shown how to derive an improved representation, which realizes cumulants through $O(\psi^4)$, by adding to the GLE a particular non-Gaussian correction. A Markovian approximation Z_{DIA}^M to Z_{DIA} is derived. Both Z_{DIA} and Z_{DIA}^M incorrectly predict a Gaussian kurtosis for the steady state of a solvable three-mode example. [S1063-651X(96)06705-0]

PACS number(s): 47.27.Ak, 03.50.-z, 05.40.+j, 52.35.Ra

I. INTRODUCTION

The importance and utility of statistical closure approximations applied to the nonlinear equations of field theory and turbulence are by now very well established [1,2]. For polynomial nonlinearities, it was natural early on to seek moment-based closures [3]. Although usually those are used to predict second-order statistics, certain of them can predict higher-order statistics as well. In particular, Chen *et al.* [4] used Kraichnan’s random-coupling model (RCM) [5] for his direct-interaction approximation (DIA) [6,5] to derive a formula for a general fourth-order statistic $Z \sim \langle (\lambda \psi^2)^2 \rangle$, where ψ is a random field, λ is a coupling coefficient that can be specified arbitrarily, and $\langle \rangle$ denotes ensemble average. [The precise definition of Z is given by Eq. 2(a) below.] Although knowledge of statistics up to only fourth order is insufficient to reconstruct structures in space and therefore to fully characterize intermittent phenomena, third- and fourth-order cumulants are natural and robust measures of the deviation of the probability density function (PDF) from Gaussian form. Unfortunately, Chen *et al.* found that the non-Gaussian corrections to a variety of important fourth-order statistics for homogeneous, isotropic, incompressible Navier-Stokes turbulence vanish in the DIA; this led them to argue for the necessity of closures based on full PDF’s rather than moments. Shortly thereafter, the theory of “mapping closures” was invented [7,8].

Although still in a relatively early stage of development, mapping closures appear to provide very successful and intriguing predictions [9] of a variety of non-Gaussian phenomena difficult to capture with moment closures. They may become a central analytical tool for studies of intermittency. Nevertheless, the moment-based approximation Z_{DIA} remains of possible interest for situations with a degree of symmetry lower than that of the canonical three-dimensional homogeneous, isotropic, incompressible Navier-Stokes problem. The present work was motivated by problems of fusion plasma physics, in which the presence of a strong confining

magnetic field introduces a natural anisotropy. In a certain useful limit, compressible, two-dimensional, anisotropic fluid models of plasma result [10,11].

I will describe the application of Z_{DIA} to the analysis of such models elsewhere. In the present work, whose goal is to clarify the conceptual foundations of Z_{DIA} , I consider the possibility of deriving Z_{DIA} by routes alternative to the one based on the RCM. First, I observe in Sec. II that the formula for Z_{DIA} [Eq. (36) below] is, in fact, contained in the seminal paper of Martin, Siggia, and Rose (MSR) [1], who presented a renormalized theory of classical statistical dynamics based on functional manipulations. That work was not cited by Chen *et al.*, and indeed a close reading of a rather difficult appendix is required in order to identify the result. Therefore, I briefly review the MSR formalism, including some discussion of the Bethe-Salpeter equation [12,2] not given explicitly by MSR. The formula for Z_{DIA} then follows immediately and elegantly, in a very general form valid for inhomogeneous systems (not considered by Chen *et al.*) and systems of n coupled fields (a particular kind of “inhomogeneous” situation). The ease with which the formula emerges demonstrates the power and beauty of the functional apparatus.

Second, I consider in Sec. III the prediction of Z made by the Langevin model of the DIA presented by Leith [13] and Kraichnan [14]. Chen *et al.* noted in passing that a generalized Langevin equation—schematically $R^{-1}\psi = b$, where R (response function) and b (random nonlinear noise) are defined later—yields the formula for Z_{DIA} for the particular case $\lambda = M$, where M is the mode-coupling coefficient for the quadratic nonlinearity of the original primitive amplitude equation. The operation that leads to that result—evaluating the mean square of the terms in the Langevin equation that represent the nonlinearity—has the advantage that it requires only the covariance of the random forcing b ; however, it does not immediately generalize to the case of arbitrary λ . An alternative procedure is to average the fourth moment of the *solution* of the Langevin equation. That, however, requires the fourth-order cumulant of the non-Gaussian b . The

original formulation of Kraichnan, in which b is represented by a particular superposition of products of random variables ξ (usually taken to be Gaussian), makes a prediction for that cumulant; however, it is easy to see that the result is not in accord with the DIA statistics of fourth order (where ‘‘DIA statistics’’ are *defined* to be those predicted by the RCM or, equivalently, by renormalized field theory in the absence of vertex renormalization). Indeed, the original Langevin model fails already at third order. I show how a partial consistency can be restored by the introduction of a particular non-Gaussian correction ψ_0 . In preparation for that discussion, I briefly review the extensions to the original MSR formalism required by non-Gaussian forcing, random coefficients, and/or initial conditions. The Kraichnan model can then be clearly seen to be compatible with only the *second-order* statistics of the DIA; it can be derived from a coupled *linear* system in the extended field $\Phi \doteq (\psi, \hat{\psi})^T$ of MSR in the limit of Gaussian b . (Here T denotes transpose; the interpretation of the operator $\hat{\psi}$ is reviewed in Sec. II.) The goal of reproducing higher-order statistics from a dynamically linear Langevin model is more problematic. At higher order, which requires non-Gaussian b , the effective equation of motion for Φ is intrinsically nonlinear and it appears to be impossible to determine the higher-order cumulants of b in a way that reproduces the complete set of higher-order correlation and response functions. However, if one is interested in reproducing only pure ψ cumulants but not higher-order response functions, it does appear to be possible, by introducing ψ_0 and $\Delta\xi \doteq \xi - \psi_0$, to specify the cross correlations of ψ_0 with Gaussian $\Delta\xi$ in a way that ensures that statistics related to ψ^3 and ψ^4 are realized correctly by the model. Nevertheless, the necessity for a non-Gaussian correction and, in general, a dynamically nonlinear model vitiates, in my opinion, the utility and heuristic clarity of the Langevin representation. Although the Leith-Kraichnan Langevin equation is physically clear and compelling as a generator of the DIA equations for second-order statistics, it still appears that the RCM is the most fundamental amplitude representation known for the DIA as interpreted to apply to statistics of all orders.

One application for which the Langevin approach is particularly well suited is the derivation of Markovian closures. In Sec. IV, I show the equivalence between a direct Markovian *Ansatz* applied to Z_{DIA} and a Langevin procedure. The application of the resulting readily computable formula to interesting problems in plasma physics will be made elsewhere.

Finally, I return in Sec. V to the solvable three-mode model introduced by Kraichnan [15] and briefly discussed by Chen *et al.* The latter authors compared the prediction of Z_{DIA} for the mean-square nonlinear term with the exact solution of the model; they found reasonable agreement. I compute instead a kurtosis constructed in a natural way from the amplitudes of the three modes. In steady state, both the DIA and the Markovian approximation incorrectly predict a vanishing non-Gaussian correction, emphasizing the inadequacy of Z_{DIA} in general.

The body of the paper concludes with a brief discussion in Sec. VI. The Appendix is devoted to the detailed construction of the kurtosis statistic in terms of Fourier amplitudes, both in general and for the solvable model.

II. FOURTH-ORDER STATISTICS FROM THE MARTIN-SIGGIA-ROSE FORMALISM

Following MSR, let us restrict our attention to quadratic nonlinearities and consider a field equation of the form

$$\partial_{t_1} \psi(1) - U_2(1,2)\psi(2) - \frac{1}{2}U_3(1,2,3)\psi(2)\psi(3) = U_1(1). \quad (1)$$

Here the argument 1 denotes the complete set of continuous and/or discrete independent variables, including, for example, a space variable x_1 , a time variable t_1 , and a discrete field label (‘‘species’’ index) s_1 ; the integration and/or summation convention for repeated indices is used. The set of all indices excluding the time will be denoted by underlining the argument, e.g., $\underline{1}$. For the time being, I take the coupling coefficients U_i to be statistically sharp; a random U_1 will be important later. The two-point generalization of the definition of Chen *et al.* is the fourth-order statistic

$$Z(\underline{1}, \bar{1}, t) \doteq \langle z(\underline{1}, t) z(\bar{1}, t) \rangle, \quad (2a)$$

where

$$z(1) \doteq \lambda(1,2,3)\psi(2)\psi(3) \quad (2b)$$

and where \doteq indicates definition. Here λ is an ‘‘external’’ coupling coefficient that can be specified arbitrarily; it should not be confused with the ‘‘internal’’ nonlinear mode-coupling coefficient $U_3 \equiv M$. I shall take λ to be local in time— $\lambda(1,2,3) \propto \delta(t_1 - t_2)\delta(t_1 - t_3)$ —although this restriction is not used until the final step of the derivation and can be easily relaxed if necessary. Clearly λ can be taken to be symmetric in its last two indices.

The fourth-order moment involved in Z ,

$$P_4(2,3,\bar{2},\bar{3}) \doteq \langle \psi(2)\psi(3)\psi(\bar{2})\psi(\bar{3}) \rangle, \quad (3)$$

has a standard cumulant expansion [16]

$$\begin{aligned} P_4(1,2,3,4) &= \langle\langle \psi(1) \rangle\rangle \langle\langle \psi(2) \rangle\rangle \langle\langle \psi(3) \rangle\rangle \langle\langle \psi(4) \rangle\rangle \\ &+ \langle\langle \psi(1) \rangle\rangle \langle\langle \psi(2) \rangle\rangle \langle\langle \psi(3)\psi(4) \rangle\rangle \\ &+ (\text{five permutations}) \\ &+ \langle\langle \psi(1) \rangle\rangle \langle\langle \psi(2)\psi(3)\psi(4) \rangle\rangle \\ &+ (\text{three permutations}) \\ &+ \langle\langle \psi(1)\psi(2) \rangle\rangle \langle\langle \psi(3)\psi(4) \rangle\rangle \\ &+ (\text{two permutations}) \\ &+ \langle\langle \psi(1)\psi(2)\psi(3)\psi(4) \rangle\rangle. \end{aligned} \quad (4)$$

Also,

$$\langle\langle \psi(1)\psi(2)\cdots\psi(n) \rangle\rangle \equiv C(1,2,\dots,n) \quad (5)$$

is the n th-order cumulant; in particular, $\langle\langle \psi \rangle\rangle = \langle \psi \rangle$ and $\langle\langle \psi(1)\psi(2) \rangle\rangle = \langle \delta\psi(1)\delta\psi(2) \rangle \equiv C(1,2)$, where $\delta\psi \doteq \psi - \langle \psi \rangle$. I assume $\langle \psi \rangle = 0$, in which case

$$P_4 = P^G + P^c, \quad (6)$$

where

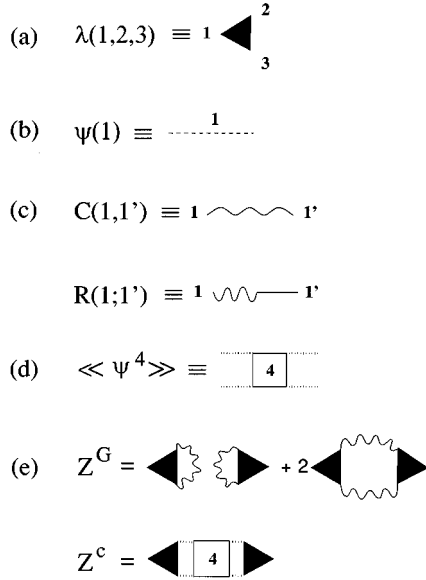

FIG. 1. Diagrammatic representation of the Z statistic. (a) External coupling coefficient $\lambda(1,2,3)$; (b) primitive amplitude ψ ; (c) correlation function $C(1,1')$ and infinitesimal response function $R(1;1')$; (d) fourth-order cumulant $\langle\langle\psi^4\rangle\rangle$; (e) decomposition of Z into a Gaussian part Z^G and a cumulant part Z^c .

$$P^G(2,3,\bar{2},\bar{3}) \doteq C(2,3)C(\bar{2},\bar{3}) + C(2,\bar{2})C(3,\bar{3}) + C(2,\bar{3})C(3,\bar{2}) \quad (7)$$

generalizes the familiar result $\langle\psi^4\rangle = 3\langle\psi^2\rangle^2$ for a univariate centered Gaussian variable ψ and where $P^c \equiv \langle\langle\psi^4\rangle\rangle$ is the fourth-order cumulant whose calculation is the goal. Diagrammatically, I represent λ by a solid triangle, ψ by a dashed line, the correlation function C by a wavy line, and the n th-order cumulant by a box with n dotted legs [Figs. 1(a)–1(d)]. The decomposition $Z = Z^G + Z^c$ induced by Eq. (6) is then shown in Fig. 1(e).

MSR argued that the moment-closure problem for classical statistical dynamics was best addressed by a symmetrical, ‘‘operator-doubled’’ formalism (a generalization of Schwinger’s approach to quantum field theory [17]) that considered C and the infinitesimal response function

$$R(1;1') \doteq \left. \frac{\delta\langle\psi(1)\rangle}{\delta h_-(1')} \right|_{h_-=0} \quad (8)$$

[Fig. 1(c)] on equal footing. [Here $\delta/\delta h_-$ denotes the functional derivative with respect to h_- , an arbitrary, statistically sharp source term added to the right-hand side of Eq. (1). The significance of the $-$ subscript will become apparent shortly.] To that end, they introduced the extended field $\Phi \doteq (\psi, \hat{\psi})^T \equiv (\Phi_+, \Phi_-)^T$, where $\hat{\psi}$ is an operator that can be thought of [18] as $-\delta/\delta\psi$ or as a momentum or Fourier-transform variable in a path-integral representation [19]. Its relationship to R will be described shortly; see Eq. (17). At equal times, ψ and $\hat{\psi}$ obey the canonical commutation relations

$$[\psi(\underline{1},t), \hat{\psi}(\underline{1}',t)] = \delta(\underline{1}-\underline{1}') \quad (9a)$$

or

$$[\Phi(\underline{1},t), \Phi(\underline{1}',t)^T] = i\sigma\delta(\underline{1}-\underline{1}'), \quad (9b)$$

where σ is a 2×2 matrix in the spinor indices $(+, -)$

$$i\sigma \doteq \begin{pmatrix} 0 & 1 \\ -1 & 0 \end{pmatrix}. \quad (10)$$

The equation of motion compatible with Eq. (1) is

$$\partial_{t_1} \hat{\psi}(1) + U_2(2,1) \hat{\psi}(2) + U_3(2,3,1) \hat{\psi}(2) \psi(3) = 0. \quad (11)$$

Equations (1) and (11) can be combined [1] into the symmetric vector equation

$$-i\sigma\dot{\Phi}(1) = \gamma_1(1) + \gamma_2(1,2)\Phi(2) + \frac{1}{2}\gamma_3(1,2,3)\Phi(2)\Phi(3), \quad (12)$$

where the arguments now include the spinor indices. Here the nonvanishing elements of the fully symmetric matrices γ_i (‘‘bare vertices’’) have precisely one minus index and are defined by $\gamma_{1-}(1) = U_1(1)$, $\gamma_{2-+}(1,2) = U_2(1,2)$, and $\gamma_{3-++}(1,2,3) = U_3(1,2,3)$.

In the original paper of MSR, the right-hand side of Eq. (12) was generated from the commutator of Φ with the Hamiltonian functional

$$\begin{aligned} \mathcal{H}_0(t_1) \doteq & \hat{\psi}(1)[U_1(1) + U_2(1,2)\psi(2) \\ & + \frac{1}{2}U_3(1,2,3)\psi(2)\psi(3)], \end{aligned} \quad (13)$$

where t_1 is not summed over. The generating functional

$$S \doteq [\exp(\Phi(\bar{1})h(\bar{1}))]_+ \quad (14)$$

was then introduced (where h is a two-dimensional vector of statistically sharp functions and the plus subscript denotes time ordering with later times to the left) and the finite- h cumulants

$$G_n^h(1,2,\dots,n) \quad (15a)$$

$$\equiv \langle\langle\Phi(1)\Phi(2)\dots\Phi(n)\rangle\rangle \quad (15b)$$

$$= \frac{\delta^n \ln\langle S \rangle}{\delta h(1)\delta h(2)\dots\delta h(n)} \quad (15c)$$

$$= \frac{\delta}{\delta h(n)} G_n^h(1,2,\dots,n-1) \quad (n > 1) \quad (15d)$$

defined. The moment hierarchy of many-time correlation and response functions was then generated by functional derivatives with respect to h of the averaged equation of motion

$$\begin{aligned} -i\sigma\dot{G}_1^h(1) = & \gamma_1(1) + h(1) + \gamma_2(1,2)G_1^h(2) + \frac{1}{2}\gamma_3(1,2,3) \\ & \times [G_1^h(2)G_1^h(3) + G_2^h(2,3)]. \end{aligned} \quad (16)$$

The physical observables (cumulants) are recovered in the limit $h \rightarrow 0$; in that limit, Eq. (16) reduces to the average of Eq. (12).

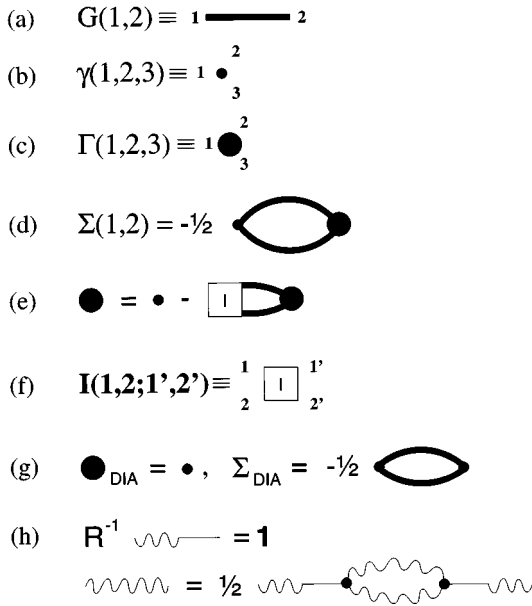

FIG. 2. Diagrammatic representation of the MSR functions. (a) Correlation matrix $G(1,2)$; (b) bare vertex function $\gamma(1,2,3)$; (c) renormalized vertex function $\Gamma(1,2,3)$; (d) mass operator $\Sigma(1,2)$; (e) vertex equation; (f) interaction kernel I ; (g) DIA in matrix form; (h) DIA as two coupled scalar equations for R and C .

The solution of Eq. (12) in terms of time-ordered evolution operators and the definition of infinitesimal response functions in terms of $\hat{\psi}$ were discussed at length by Rose [18]. The key technical result is that [18]

$$R(1;1') = \langle\langle \psi(1) \hat{\psi}(1') \rangle\rangle_+ . \quad (17)$$

The time-ordering convention ensures that any cumulant beginning with $\hat{\psi}$ on the left will vanish; as a special case, it guarantees causality of the infinitesimal response: $R(t;t') \propto H(t-t')$, where H is the Heaviside unit step function. Then the time-ordered two-point correlation matrix $G \equiv G_2$ is built from just C and R :

$$G(1,2) \doteq \langle\langle \Phi(1)\Phi(2) \rangle\rangle_+ = \begin{pmatrix} C(1,2) & R(1;2) \\ R(2;1) & 0 \end{pmatrix}. \quad (18)$$

Diagrammatically, G is represented by a heavy solid line [Fig. 2(a)]. Higher-order Φ cumulants have natural physical interpretations as well. For example, $R(1;1',1'') \doteq \langle\langle \psi(1) \hat{\psi}(1') \hat{\psi}(1'') \rangle\rangle_+$ is the ‘‘two in, one out’’ infinitesimal response function.

More recently, Jensen [19], following earlier work by Janssen [20], DeDominicis [21], and Phythian [22], discussed a path-integral interpretation of the MSR formalism. This approach permits certain generalizations that are cumbersome to treat by the MSR techniques as described by Rose [18]. Jensen showed, for example, that

$$-i\sigma \langle\langle \dot{\Phi}(1) \rangle\rangle^h = \langle S \rangle^{-1} \frac{\delta \bar{\mathcal{H}}}{\delta \Phi(1)} + h(1), \quad (19)$$

where

$$\bar{\mathcal{H}} \doteq \ln \langle \exp \mathcal{H} \rangle, \quad (20a)$$

$$\mathcal{H} = \mathcal{H}_0 + (\text{an initial-condition term}), \quad (20b)$$

$$\begin{aligned} \mathcal{H}_0 \doteq & \gamma_1(1)\Phi(1) + \frac{1}{2!} \gamma_2(1,2)\Phi(1)\Phi(2) \\ & + \frac{1}{3!} \gamma_3(1,2,3)\Phi(1)\Phi(2)\Phi(3). \end{aligned} \quad (20c)$$

[In contrast to Eq. (13), all times are integrated over in Eq. (20c).] This approach permits easy consideration of random vertices and initial conditions. Further discussion of this point is given in Sec. III B 2.

For now, I continue to consider Gaussian initial conditions and statistically sharp vertices (important restrictions that are relaxed in Sec. III B 2). Closure of the hierarchy of moment equations in terms of the formally exact Dyson equation for G is effected by changing variables from h to F^h (where $F \equiv G_1 \doteq \langle \Phi \rangle$), best described formally in terms of Legendre transforms [23,2]. This leads to the natural introduction of the (matrix) three-point renormalized vertex function

$$\Gamma(1,2,3) \doteq - \frac{\delta G^{-1}(1,2)}{\delta \langle \Phi(3) \rangle}. \quad (21)$$

(I now drop the h superscript where no confusion can arise.) It is readily shown that

$$\Gamma(1,2,3) = G^{-1}(1,\bar{1})G^{-1}(2,\bar{2})G^{-1}(3,\bar{3})G(\bar{1},\bar{2},\bar{3}), \quad (22)$$

so Γ is fully symmetric; it is represented diagrammatically by a large dot, whereas the bare three-point vertex γ is represented by a small dot [Figs. 2(b) and 2(c)]. One finds

$$\begin{aligned} G^{-1}(1,2) = & -i\sigma \partial_{t_1} \delta(1-2) - \gamma(1,2) - \gamma(1,2,3)\langle \Phi(3) \rangle \\ & + \Sigma(1,2), \end{aligned} \quad (23)$$

where [24]

$$\Sigma(1,\bar{1}) = -\frac{1}{2} \gamma(1,2,3)G(2,\bar{2})G(3,\bar{3})\Gamma(\bar{1},\bar{2},\bar{3}) \quad (24)$$

[Fig. 2(d)]. Finally, an independent equation for Γ follows by functional differentiation of the Dyson equation (23):

$$\Gamma_3 = \gamma_3 - I_4 G_2 G_2 \Gamma_3 \quad (25)$$

[Fig. 2(e)], where

$$I_4(1,2;1',2') \doteq \left. \frac{\delta \Sigma(1,2)}{\delta G(1',2')} \right|_F \quad (26)$$

[Fig. 2(f)]. Renormalized (Eulerian) statistical closures can now be generated by approximating the interaction kernel $I \equiv I_4$, which can be expressed as a power series in Γ [25]. The lowest-order closure

$$\Gamma \approx \gamma \quad (27)$$

[Fig. 2(g)], is the most common formal definition of Kraichnan’s famous DIA, i.e., the DIA omits vertex renormalization [5].

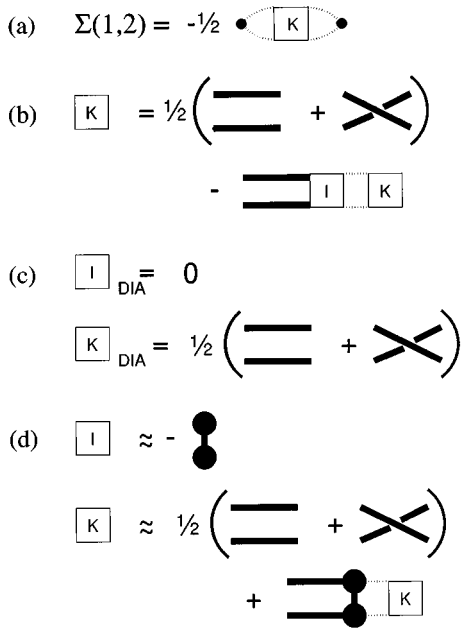

FIG. 3. Two-particle scattering matrix and the Bethe-Salpeter equation. (a) Mass operator $\Sigma(1,2)$; (b) Bethe-Salpeter equation; (c) DIA; (d) first vertex renormalization.

Although expressing all results in terms of Γ is often sufficient, the formula $\Sigma = -\frac{1}{2}\gamma G G \Gamma$ is not manifestly symmetric. For many purposes, including a discussion of fourth-order statistics, it is better to use the alternative, manifestly symmetric representation discussed in Appendix A of Ref. [1]:

$$\Sigma = -\frac{1}{2}\gamma K \gamma \quad (28)$$

[Fig. 3(a)], where K , the “two-particle scattering matrix,” obeys the Bethe-Salpeter equation (BSE) [12,2]

$$K = (GG)_s - GGIK, \quad (29)$$

where the subscript s denotes symmetrization [Fig. 3(b)]. Here I represents the intrinsic two-particle interactions, another way of describing the effects of vertex renormalization. The most symmetric formal way of introducing the various terms in the BSE is again by means of (two-point) Legendre transforms [12,2]; however, I shall not review the details here since I need only the results, already presented by MSR. The DIA is $I \approx 0$ or $K \approx (GG)_s$ [Fig. 3(c)]; the next approximation (first vertex renormalization) is $I \approx -\Gamma G \Gamma$ [Fig. 3(d)]. The up-down connected nature of I , a signature of vertex corrections, will be important shortly.

MSR show [their Eq. (A6)] that

$$\begin{aligned} G_4(1,2,3,4) = & 2[\delta G_2(1,2)/\delta \gamma_2(3,4)]_{G_1} - G_2(1,4)G_2(2,3) \\ & - G_2(1,3)G_2(2,4) \\ & + G_2(1,\bar{1})G_2(2,\bar{2})\Gamma_3(\bar{1},\bar{2},\bar{5})G_2(\bar{5},\bar{6}) \\ & \times \Gamma_3(\bar{6},\bar{3},\bar{4})G_2(\bar{3},\bar{3})G_2(\bar{4},\bar{4}), \end{aligned} \quad (30)$$

the interpretation of which is [1] “the set of graphs involving 1, 2, 3, 4 that cannot be divided into two parts by cutting a

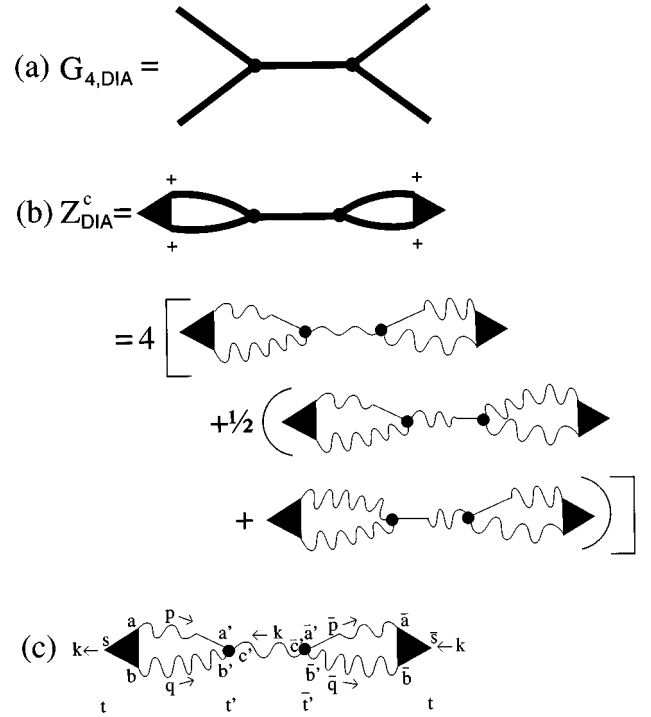

FIG. 4. DIA contribution to fourth-order cumulant. (a) $G_{4,\text{DIA}}$; (b) Z_{DIA}^c ; (c) Fourier transform of Z_{DIA}^c . Only the first term of (b) is shown explicitly; the other terms have identical structure.

single line... is equal to $G_4(1,2,3,4)$ minus the last term in [Eq. (30)].” Because those graphs are precisely the vertex effects not contained in the DIA, it must be true that the last term of Eq. (30) is (for $\Gamma \rightarrow \gamma$) the DIA for G_4 :

$$G_{4,\text{DIA}} = GG\gamma G\gamma GG \quad (31)$$

[Fig. 4(a)] [26]. Therefore, upon recalling Eqs. (2) and (6), one obtains one of the central results of this paper:

$$Z_{\text{DIA}}^c = \lambda GG\gamma G\gamma GG\lambda, \quad (32)$$

where, by definition of Z as being proportional to ψ^4 , the λ 's fix the outermost spinor indices to be +; internal indices must be summed over. One may now recall that γ is fully symmetric, but nonvanishing only when precisely one of its indices is -. The complete set of diagrams that follow from Eq. (32), taking account of the symmetries of λ and γ , is shown in Fig. 4(b). It is readily seen that these reproduce the formula for Z^c of Chen *et al.* More specifically, let $1 \equiv \{x_1, s_1, t_1\}$ (ignoring, e.g., a momentum variable that would arise, say, in a discussion of Vlasov turbulence, assume homogeneity in space, and Fourier transform. I use the convention (compatible with statistical homogeneity)

$$\lambda(x, y, z) = \hat{\lambda}(y - x, z - x), \quad (33a)$$

where

$$\hat{\lambda}(\rho_1, \rho_2) = \sum_{p,q} \exp(ip \cdot \rho_1 + iq \cdot \rho_2) \hat{\lambda}_{p,q}. \quad (33b)$$

With this convention, the complete Fourier transform of $\lambda(x, y, z)$ is

$$\lambda_{k,p,q} = \delta_{k+p+q} \hat{\lambda}_{p,q}, \quad (34)$$

where $\delta_k \equiv \delta_{k,0}$. I use the same convention for M . A conse-

quence is that the three wave vectors entering a vertex must sum to zero. Upon writing

$$R_k(s, t; s', t') = H(t - t') \hat{R}_k(s, t; s', t') \quad (35)$$

[$\hat{R}(t'; t') = 1$, whereas $R(t'; t') = 1/2$], one then expands Eq. (32) to

$$\begin{aligned} Z_{\text{DIA},k}^c(s, \bar{s}, t) = & 4 \sum_{\substack{p,q \\ a,b}} \sum_{\substack{\bar{p}, \bar{q} \\ \bar{a}, \bar{b}}} \sum_{c', \bar{c}'} \left\{ d_{k,p,q}(s, a, b; c', a', b') d_{k,\bar{p},\bar{q}}^*(\bar{s}, \bar{a}, \bar{b}; \bar{c}', \bar{a}', \bar{b}') \right. \\ & \times \int_0^t dt' \int_0^{t'} d\bar{t}' \hat{R}_p(a, t; a', t') C_q(b, t; b', t') C_k^*(c', t'; \bar{c}', \bar{t}') \hat{R}_{\bar{p}}^*(\bar{a}, t; \bar{a}', \bar{t}') C_{\bar{q}}^*(\bar{b}, t; \bar{b}', \bar{t}') \\ & + \left[d_{k,p,q}(s, a, b; c', a', b') c_{k,\bar{p},\bar{q}}^*(\bar{s}, \bar{a}, \bar{b}; \bar{c}', \bar{a}', \bar{b}') \right. \\ & \left. \left. \times \int_0^t dt' \int_0^{t'} d\bar{t}' \hat{R}_p(a, t; a', t') C_q(b, t; b', t') \hat{R}_k^*(c', t'; \bar{c}', \bar{t}') C_{\bar{p}}^*(\bar{a}, t; \bar{a}', \bar{t}') C_{\bar{q}}^*(\bar{b}, t; \bar{b}', \bar{t}') \right]^H \right\} \quad (36) \end{aligned}$$

[Fig. 4(c)], where

$$\begin{aligned} c_{k,p,q}(s, a, b; s', a', b') & \doteq \lambda(s, \mathbf{k}; a, \mathbf{p}; b, \mathbf{q}) M^*(s', \mathbf{k}; a', \mathbf{p}; b', \mathbf{q}) \\ & = \delta_{k+p+q} \hat{\lambda}_{p,q}(s, a, b) \hat{M}_{p,q}^*(s', a', b'), \quad (37a) \end{aligned}$$

$$\begin{aligned} d_{k,p,q}(s, a, b; s', a', b') & \doteq \lambda(s, \mathbf{k}; a, \mathbf{p}; b, \mathbf{q}) M^*(a', \mathbf{p}; b', \mathbf{q}; s', \mathbf{k}) \\ & = \delta_{k+p+q} \hat{\lambda}_{p,q}(s, a, b) \hat{M}_{q,k}^*(a', b', s'), \quad (37b) \end{aligned}$$

and

$$A_{p,q;\bar{p},\bar{q}}^H(s, s') \doteq \frac{1}{2} [A_{p,q;\bar{p},\bar{q}}(s, s') + A_{\bar{p},\bar{q};p,q}^*(s', s)]. \quad (38)$$

In lieu of the preceding, relatively advanced discussion based on the Bethe-Salpeter equation, one may give the following (equivalent) derivation [27]. One has $G_4 = \delta G_3 / \delta h$ or [upon recalling Eqs. (22) and (15d)]

$$G_4 = \frac{\delta}{\delta h} (GGG\Gamma) \quad (39a)$$

$$= G_3 GGG\Gamma + GG_3 G\Gamma + GGG_3 \Gamma + GGG \frac{\delta \Gamma}{\delta h} \quad (39b)$$

(Fig. 5). Upon considering the expansion of $\delta \Gamma / \delta h$, one concludes that all terms of Eq. (39b) except the first involve the up-down connected part $\Gamma G \Gamma$, hence are absent from the DIA [26]. For $\Gamma \approx \gamma$ and with the aid of Eq. (22), one verifies that the first term of Eq. (39b) is just formula (31). In that same approximation, the first three terms of Eq. (39b) are well known in quantum field theory; cf. Ref. [28], Fig. 6.1.1.

The simplicity of the derivations of either Eq. (30) or Eq. (39b) stems from two features: (i) the nature of cumulants as functional derivatives and (ii) the symmetric, matrix nature

of the MSR formalism. Thus one derives the single compact formula (32) [first line of Fig. 4(b)], which expands immediately into Eq. (36) [second line of Fig. 4(b)]. Of course, the same features lead to the single matrix Dyson equation [1], which expands into two coupled scalar equations for C and R [Fig. 2(h)]; likewise, Σ has several elements, one describing [29] emission ($-\Sigma_{++}$), the other (typically) describing absorption (Σ_{-+}). The presence of both Σ_{++} and Σ_{-+} is required in order that energylike conservation theorems can be maintained. (For a discussion of this well-known point in the context of plasma physics, see Ref. [30].)

III. REALIZABLE LANGEVIN MODELS AND THE DIA

Although the DIA can be simply and concisely characterized as the absence of vertex renormalization, this does not in itself imply that the DIA is well behaved. Indeed, soon after presenting the DIA, Kraichnan described a variety of ‘‘similar’’ renormalized closures that, although graphically plausible, exhibited badly divergent behavior [5]. He was led to stress the importance of satisfying the infinity of realizability inequalities [31] that moments of a PDF must obey. In particular, he discussed the desirability of finding a stochastic amplitude equation whose statistics precisely reproduce those of the closure in question (at least through some order). An underlying amplitude representation guarantees that a PDF exists, hence that the closure cannot violate the realiz-

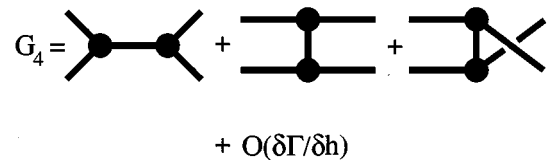

FIG. 5. Contributions to G_4 .

$$(a) \quad \xi = \dots\dots\dots$$

$$(b) \quad \psi = \frac{1}{2} \text{---} \bullet \text{---}$$

FIG. 6. Original Langevin representation for ψ . (a) Auxiliary field ξ ; (b) Langevin representation.

ability inequalities. For example, in a realizable closure covariances must remain positive definite.

Kraichnan showed that the DIA is derivable from several varieties of random-coupling models [32,5,33], built most fundamentally from an infinite number of copies of a random amplitude equation stochastically coupled together in a particular way [5]. (Essentially, the mode-coupling coefficient of the original quadratic nonlinearity is randomized, thus producing a model dynamical equation cubically nonlinear in stochastic variables.) Chen *et al.* used the RCM to derive their result for Z_{DIA} .

A. The standard Langevin model for the DIA

Some time after the original RCM was presented, a Langevin representation for the two-point Dyson equations of the DIA was demonstrated by Leith [13] and Kraichnan [14]. For the specific, Fourier-transformed amplitude equation

$$\frac{\partial \psi_k}{\partial t} + \nu_k \psi_k = \frac{1}{2} \sum_{\Delta} M_{k,p,q} \psi_p^* \psi_q^* + h_k, \quad (40)$$

where ν_k represents linear physics and \sum_{Δ} denotes the sum over all \mathbf{p} and \mathbf{q} such that $\mathbf{k} + \mathbf{p} + \mathbf{q} = \mathbf{0}$, Kraichnan's original form of the Langevin equation was

$$(\partial_t + \nu_k + \Sigma_k \star) \psi_k \equiv R_k^{-1} \psi_k \quad (41a)$$

$$= \frac{1}{2} \sum_{\Delta} M_{k,p,q} \xi_p^*(t) \xi_q^*(t) + h_k, \quad (41b)$$

where Σ_k is the nonlinear damping term Σ_{-+} appearing in the DIA, \star denotes convolution in time, and ξ is a random variable (not necessarily Gaussian, but independent of ψ) whose covariance is fixed to be that of ψ itself. It is readily shown that the second-order statistics of this amplitude representation coincide with those of the DIA. To review the argument, one first notes that the result

$$R^{-1} \frac{\delta \psi(t)}{\delta h(t')} = \delta(t-t') \quad (42)$$

(ξ is independent of h , since it is independent of ψ^h) guarantees that the infinitesimal response function of the model is that of the DIA. Next, the covariance equation is formed and shown to agree with that of the DIA. Specifically, upon writing the solution $\psi = R(\frac{1}{2} M \xi \xi)$, shown diagrammatically in Fig. 6(b), one finds

$$\begin{aligned} Z &= \left(\frac{1}{2}\right)^4 \left\langle \left(\text{---} \bullet \text{---} \right) \left(\text{---} \bullet \text{---} \right) \right\rangle \\ &= \frac{1}{4} \left[\text{---} \bullet \text{---} \right] + \frac{1}{2} \left[\text{---} \bullet \text{---} \right] + \frac{1}{2} \left[\text{---} \bullet \text{---} \right] + \frac{1}{2} \left[\text{---} \bullet \text{---} \right] \end{aligned}$$

FIG. 7. Calculation of Z from the original Langevin representation. The first two diagrams represent the Gaussian contribution; the last two represent vertex corrections omitted in the DIA.

$$C(1,1') = R(1;\bar{1}) F(\bar{1},\bar{1}') R(1';\bar{1}'), \quad (43a)$$

where

$$F(1,\bar{1}) \doteq \frac{1}{2} M(1,2,3) M(\bar{1},\bar{2},\bar{3}) C(2,\bar{2}) C(3,\bar{3}); \quad (43b)$$

this is the familiar spectral balance equation for the DIA covariance [2] [Fig. 2(h)].

At this point one must distinguish between two possible interpretations of the ‘DIA’: either (i) the two familiar coupled equations for R and C (second-order statistics) or (ii) the renormalized closure that neglects vertex renormalization. The latter interpretation is clearly the more general; it admits the calculations of higher-order statistics, as we have seen. However, while the Langevin model (41b) successfully reproduces the second-order statistics of the DIA, it does *not* do so for higher-order ones. The difficulty is already present at third order (see Sec. III D below), but to make immediate contact with the previous calculations, I consider the fourth order and calculate Z from Eq. (41b). This is easy to do diagrammatically; see Fig. 7. The first two diagrams reduce, with the aid of the spectral balance equation (43), to the Gaussian contributions to Z ; however, the last two diagrams are *not* equivalent to Eq. (32). Indeed, the presence of up-down correlations, or the fact that two horizontal lines must be cut to bisect the graphs, identifies the last two diagrams as stemming from vertex corrections omitted in the DIA. (There are other such vertex corrections of the same order that the present Langevin model does not predict.)

The failure of Eq. (41b) to successfully reproduce a specified set of higher-order statistics is not surprising, since it was constructed with realizability of only the second-order statistics of the DIA in mind. Indeed, the PDF of $\psi \sim M \xi^2$ is a generalized χ^2 distribution—non-Gaussian, to be sure, but

not the infinitely richer non-Gaussian PDF compatible with the DIA statistics through all orders [34].

Chen *et al.* discussed a more general form of the Langevin model,

$$R^{-1}\psi = b, \tag{44}$$

in which the covariance of the random forcing b is constrained to be

$$\langle b(1)b(2) \rangle = F(1,2), \tag{45}$$

but is not required to be of product form. As discussed in Sec. I, they showed that the mean square of the terms in Eq. (44) that represent the nonlinearity (i.e., $b - \Sigma \star \psi$) reproduces formula (32) for the special case $\lambda = M$. This is an important and necessary consistency check. However, they did not attempt a Langevin-based calculation of Z_{DIA} for arbitrary λ .

B. Generalized Langevin models, non-Gaussian statistics, and effective equations of motion

I shall now discuss the possibility of generalizing the Langevin model in such a way that higher-order statistics of the DIA are predicted correctly. The attempt will not be entirely successful, although it is instructive. The remainder of Sec. III is rather technical; readers can skip, without loss of continuity, directly to Sec. IV if they desire.

I. A non-Gaussian correction

It is useful to retain a nonlinear term of the product form (41b) because of its heuristic appeal. However, it is easy to verify that such a term will not by itself generate the proper higher-order statistics. To correct for the difference in non-Gaussian statistics, I introduce a new non-Gaussian random variable ψ_0 , statistically dependent on ξ and satisfying $\langle \psi_0 \rangle = 0$, and write

$$\psi = \psi_0 + R[\frac{1}{2}M(\xi - \psi_0)(\xi - \psi_0)] \tag{46a}$$

or, with $\Delta\psi \doteq \psi - \psi_0$ and $\Delta\xi \doteq \xi - \psi_0$,

$$R^{-1}\Delta\psi = \frac{1}{2}M\Delta\xi\Delta\xi. \tag{46b}$$

Here R is again the response function of the DIA. I now redefine the model such that $\Delta\xi$ (not ξ) is Gaussian with covariance fixed to that of ψ (not $\Delta\psi$). The statistical properties of ψ_0 are to be determined. That a representation of the form (46a) (i.e., ψ being the sum of two non-Gaussian random variables) is possible is guaranteed if the statistical closure is realizable; one is thus fortunate in being aware of the RCM, which guarantees realizability of the DIA statistics through all orders.

The utility of the added freedom afforded by ψ_0 is apparent upon considering the evaluation of $\langle \psi^4 \rangle = \langle (\psi_0 + R\frac{1}{2}M\Delta\xi^2)^4 \rangle$, which involves various mixed cumulants such as $\langle \langle \psi_0\Delta\xi \rangle \rangle$, $\langle \langle \psi_0\Delta\xi^3 \rangle \rangle$, and $\langle \langle \psi_0^2\Delta\xi^2 \rangle \rangle$. One can attempt to assign consistent values to the $\psi_0 - \Delta\xi$ cumulants in a way such that DIA statistics involving ψ^n ($n \leq$ a fixed number such as 4) are reproduced (and also that the appropriate realizability inequalities are satisfied). However, there

is also the question of whether the higher-order response functions (cumulants involving at least one $\hat{\psi}$) are properly dealt with. The most systematic way of treating all of these issues is to employ the non-Gaussian version of the MSR formalism. I describe that briefly in the next section.

2. Non-Gaussian effects in the MSR formalism

The original work of MSR dealt only with Gaussian initial conditions (that restriction is perhaps not obvious, but see the paragraph just before Sec. III of Ref. [1]) and statistically sharp coupling coefficients. Modifications for non-Gaussian initial conditions and random coefficients were described by Rose [18], Deker and Haake [23], Phythian [35], Deker [36], and Jensen [19]. Jensen’s work is perhaps the most general; it embraces not only random initial conditions but also random coupling coefficients of arbitrary order. Rose [37] proposed an efficiently computable closure in which the full time-history integrals of the DIA were replaced by truncated ones that explicitly allowed for non-Gaussian effects.

The original Langevin representation of the DIA provides a simple example of a random, non-Gaussian coupling coefficient. One can write Eq. (41b) in the form

$$\partial_{t_1}\psi(1) - U_2(1,2)\psi(2) = h(1) + \tilde{U}_1(1), \tag{47}$$

where

$$U_2(1,2) = -[\nu(\underline{1},\underline{2})\delta(t_1 - t_2) + \Sigma(1,2)] \tag{48a}$$

describes both linear effects and the mean nonlinear damping, and

$$\tilde{U}_1(1) \doteq \frac{1}{2}U_3(1,2,3)\xi(2)\xi(3) \equiv b. \tag{48b}$$

Equation (47) has no term dynamically nonlinear in ψ ; the effect of the nonlinearity has been replaced by the random (non-Gaussian) forcing $\tilde{U}_1(1)$. It is an example of a stochastic differential equation driven by non-Gaussian noise.

Generalizing earlier work of Rose [18], Jensen [19] showed that for random U_1 the Hamiltonian functional (20a) becomes

$$\bar{\mathcal{H}} = \bar{\mathcal{H}}_0 + \langle \mathcal{E}\{\hat{\psi}\} \rangle, \tag{49}$$

where the cumulant functional \mathcal{E} is given by

$$\mathcal{E}\{\hat{\psi}\} \doteq \sum_{n=1}^{\infty} \frac{1}{n!} \hat{\psi}(1) \cdots \hat{\psi}(n) U_n^{(0)}(1, \dots, n) \tag{50}$$

and the ‘‘spurious vertices’’ [18] (denoted by the superscript 0) are

$$U_n^{(0)}(1, \dots, n) \doteq \langle \langle \tilde{U}_1(1) \cdots \tilde{U}_1(n) \rangle \rangle. \tag{51}$$

This results in a modified equation of motion derivable from Eq. (12) by replacing [18] $\gamma_n \rightarrow \gamma_n + \Gamma_n^{(0)}$, where $\Gamma_n^{(0)}$ is non-vanishing only when all of its spinor indices are $-$ (in which case its value is $U_n^{(0)}$, the n th cumulant of \tilde{U}_1).

The specific equation of motion that follows from Eq. (47) (for which $\gamma_{n \geq 3} \equiv 0$) is

$$\begin{aligned}
-i\sigma\dot{G}_1^h(1) &= h(1) + \Gamma_1^{(0)}(1) + [\gamma_2(1,2) + \Gamma_2^{(0)}(1,2)]G_1^h(2) + \frac{1}{2!}\Gamma_3^{(0)}(1,2,3)[G_1^h(2)G_1^h(3) + G_2^h(2,3)] + \frac{1}{3!}\Gamma_4^{(0)}(1,2,3,4) \\
&\times [G_1^h(2)G_1^h(3)G_1^h(4) + 3G_1^h(2)G_2^h(3,4) + G_3^h(2,3,4)] + \frac{1}{4!}\Gamma_5^{(0)}(1,2,3,4,5)[G_1^h(2)G_1^h(3)G_1^h(4)G_1^h(5) \\
&+ 6G_1^h(2)G_1^h(3)G_2^h(4,5) + 4G_1^h(2)G_3^h(3,4,5) + 3G_2^h(2,3)G_2^h(4,5) + G_4^h(2,3,4,5)] + O(\Gamma_6^{(0)}), \quad (52)
\end{aligned}$$

where the complete symmetry of $\Gamma_n^{(0)}$ was used to combine some terms. The facts that the $\Gamma^{(0)}$ have only $-$ indices and that cumulants with all $-$ indices vanish identically for $h=0$ mean that the equation for the mean field is

$$-i\sigma\langle\dot{\Phi}(1)\rangle - \gamma_2(1,2)\langle\Phi(2)\rangle = \begin{pmatrix} 0 \\ \langle b \rangle \end{pmatrix}. \quad (53)$$

I shall take $\langle b \rangle = 0$, so consistently $\langle \psi \rangle = 0$. Higher-order cumulants follow in the usual way by functional differentiation of Eq. (52). The covariance obeys

$$\begin{aligned}
-i\sigma\dot{G}_2^h(1,1') &= \delta(1-1') + [\gamma_2(1,2) + \Gamma_2^{(0)}(1,2)]G_2^h(2,1') + \frac{1}{2!}\Gamma_3^{(0)}(1,2,3)[2G_1^h(2)G_2^h(3,1') + G_3^h(2,3,1')] + \frac{1}{3!}\Gamma_4^{(0)}(1,2,3,4) \\
&\times [3G_1^h(2)G_1^h(3)G_2^h(4,1') + 3G_2^h(2,3)G_2^h(4,1') + 3G_1^h(2)G_3^h(3,4,1') + G_4^h(2,3,4,1')] + \frac{1}{4!}\Gamma_5^{(0)}(1,2,3,4,5) \\
&\times [4G_1^h(2)G_1^h(3)G_1^h(4)G_2^h(5,1') + 6G_1^h(2)G_1^h(3)G_3^h(4,5,1') + 4G_1^h(2)G_4^h(3,4,5,1') + 4G_2^h(2,1')G_3^h(3,4,5) \\
&+ 6G_2^h(2,3)G_3^h(4,5,1') + G_5^h(2,3,4,5,1')] + O(\Gamma_6^{(0)}). \quad (54)
\end{aligned}$$

Upon setting $h=0$, one finds that the physical covariance matrix obeys

$$\begin{aligned}
-i\sigma\dot{G}_2(1,1') &= \delta(1-1') + [\gamma_2(1,2) + \Gamma_2^{(0)}(1,2)]G_2(2,1') + \frac{1}{2!}\Gamma_3^{(0)}(1,2,3)G_3(2,3,1') + \frac{1}{3!}\Gamma_4^{(0)}(1,2,3,4)G_4(2,3,4,1') \\
&+ \frac{1}{4!}\Gamma_5^{(0)}(1,2,3,4,5)G_5(2,3,4,5,1') + O(\Gamma_6^{(0)}). \quad (55)
\end{aligned}$$

Upon recalling Eqs. (48), one finds that the $(-, -)$ component of Eq. (55) is

$$\frac{\partial}{\partial t}R + (\nu + \Sigma \star)R = \delta(t-t') \quad (56a)$$

and the $(-, +)$ component is

$$\frac{\partial}{\partial t}C + (\nu + \Sigma \star)C = \langle\langle bb \rangle\rangle R^{\text{Tr}} + \Delta_2, \quad (56b)$$

where

$$\begin{aligned}
\Delta_2(1,1') &\doteq \sum_{n=3}^{\infty} \frac{1}{(n-1)!} U_n^{(0)} \\
&\times (1, \dots, n) G_{n-, \dots, -+}(2, \dots, n, 1'). \quad (57)
\end{aligned}$$

The system (56) obviously reproduces the usual two-point DIA equations if the covariance of b is chosen according to Eq. (45) and if

$$\Delta_2 \doteq 0. \quad (58)$$

For Gaussian b , $U_{n \geq 3}^{(0)} = 0$ and the constraint (58) is automatically satisfied.

For the Gaussian case, Eqs. (56) follow from the effective equation of motion

$$-i\sigma\dot{\Phi} - (\gamma_2 + \Gamma_2^{(0)})\Phi = h \quad (59)$$

or, in particular, for $h=0$,

$$\dot{\psi} + (\nu + \Sigma \star)\psi = \langle\langle bb \rangle\rangle \hat{\psi}, \quad (60a)$$

$$\hat{\dot{\psi}} + (\nu^* + \Sigma^\dagger \star)\hat{\psi} = 0, \quad (60b)$$

a coupled *linear* system. This is the dynamical linearity of the original Langevin representation seen in another guise.

For non-Gaussian b , linearity is lost, since higher-order statistics are required. An effective equation of motion that includes the effect of the third-order cumulant is

$$-i\sigma\dot{\Phi} - (\gamma_2 + \Gamma_2^{(0)})\Phi - \frac{1}{2}\Gamma_3^{(0)}\Phi\Phi = h \quad (61)$$

or, for $h=0$,

$$\dot{\psi} + (\nu + \Sigma \star)\psi = \langle\langle bb \rangle\rangle \hat{\psi} + \frac{1}{2}\langle\langle bbb \rangle\rangle \hat{\psi}\hat{\psi}, \quad (62)$$

along with Eq. (60b). The nonlinear structure of this coupled system is qualitatively different from the previous linear one.

It would appear that the nonlinearity inherent with non-Gaussian b precludes a linear Langevin model of the form $R^{-1}\psi=b$ that will faithfully reproduce all DIA correlation and response functions through any given order higher than second. Difficulty arises from the constraint (58) and from additional constraints to be identified shortly. The linear relation $\psi=Rb$ means [from Eqs. (48b) and (51)] that

$$\begin{aligned} -i\sigma\dot{G}_3(1,1',1'') &= (\gamma_2 + \Gamma_2^{(0)})(1,2)G_3(2,1',1'') + \frac{1}{2}\Gamma_3^{(0)}(1,2,3)[2G_2(2,1')G_2(3,1'') + G_4(2,3,1',1'')] \\ &+ \frac{1}{3!}\Gamma_4^{(0)}(1,2,3,4)[3G_2(2,1')G_3(3,4,1'') + 3G_2(2,1'')G_3(3,4,1') + G_5(2,3,4,1',1'')] \\ &+ \frac{1}{4!}\Gamma_5^{(0)}(1,2,3,4,5)[4G_2(2,1')G_4(3,4,5,1'') + 4G_2(2,1'')G_4(3,4,5,1') + 6G_3(2,3,1')G_3(4,5,1'') \\ &+ 6G_2(2,3)G_4(4,5,1',1'') + G_6(2,3,4,5,1',1'')] + O(\Gamma_6^{(0)}). \end{aligned} \quad (64)$$

The predictions of this equation must be compatible with the already-known DIA result [see Eqs. (22) and (27)]

$$G_3 = G_2 G_2 G_2 \gamma \quad (65)$$

[Fig. 8(a)]. This sets values for the three independent third-order cumulants G_{3+++} , G_{3+--} , and G_{3+-} [Fig. 8(b)]; recall that G_{3---} vanishes identically. The appropriate components of Eq. (64) lead, with the aid of the already determined result (45), to equations that are compatible with Eq. (65) only if new constraints on the $\Gamma_n^{(0)}$ are satisfied. I will not write those out in detail, but again it does not appear that they are compatible with the dynamics of the DIA.

One concludes, then, that a linear Langevin model of the form $R^{-1}\psi=b$ is too simplistic to capture all features of the DIA (i.e., statistics of both fluctuations and response through all orders), no matter what the statistical distribution of b is. However, one may pose the restricted question of whether an appropriate representation of b can reproduce pure ψ statistics through a given order. This question can be answered in the affirmative, since one knows from the RCM that the DIA statistics are realizable and in the linear Langevin model one has $b \propto \psi$. In the following section, I comment briefly on how the representation (46) can be used to efficiently determine Langevin constraints compatible with low-order DIA statistics.

C. Second-order statistics

Although we are ultimately interested in fourth-order statistics, it is useful to illustrate the formalism and to derive some necessary results by first considering the second- and third-order statistics of ψ , given the decomposition (46). Upon denoting ψ_0 by a dashed line, one can represent Eq. (46a) by Fig. 9(a). One has

$$U_n^{(0)}(1, \dots, n) = (R^{-1})^n \langle \langle \psi(1) \dots \psi(n) \rangle \rangle. \quad (63)$$

Constraints such as (58) thus relate products of correlation and response functions of different orders, but in a way that does not appear to be compatible with the dynamics of the DIA itself.

A further example of such constraints emerges from the equation for G_3 that follows from Eq. (54). Upon again recalling that $\Gamma_n^{(0)}$ has all $-$ indices, one finds for $h=0$

$$\begin{aligned} \langle \psi \psi \psi \rangle &= \langle \psi_0 \psi_0 \rangle + \langle \psi_0 (R \frac{1}{2} M \Delta \xi \Delta \xi) \rangle + \langle (R \frac{1}{2} M \Delta \xi \Delta \xi) \psi_0 \rangle \\ &+ \langle (R \frac{1}{2} M \Delta \xi \Delta \xi) (R \frac{1}{2} M \Delta \xi \Delta \xi) \rangle \end{aligned} \quad (66)$$

[Fig. 9(b)]. It is convenient to normalize ψ_0 such that

$$\langle \psi_0 \psi_0 \rangle = \langle \psi \psi \rangle \equiv C. \quad (67)$$

The sum of the last three terms on the right-hand side of Eq. (66) must therefore vanish; this provides a constraint on the third-order multivariate statistics of ψ_0 and $\Delta \xi$:

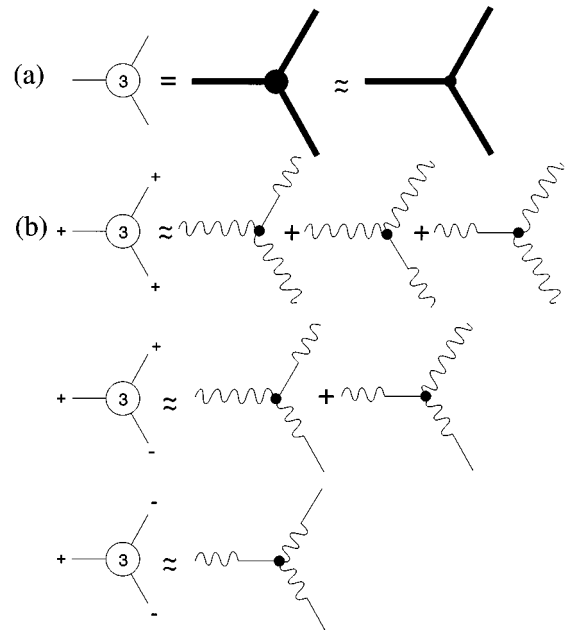

FIG. 8. Third-order cumulants in the DIA. (a) Exact expression $G_3 = GGG\Gamma$ and its DIA approximation $G_3 \approx GGG\gamma$; (b) nonvanishing components of G_3 in the DIA.

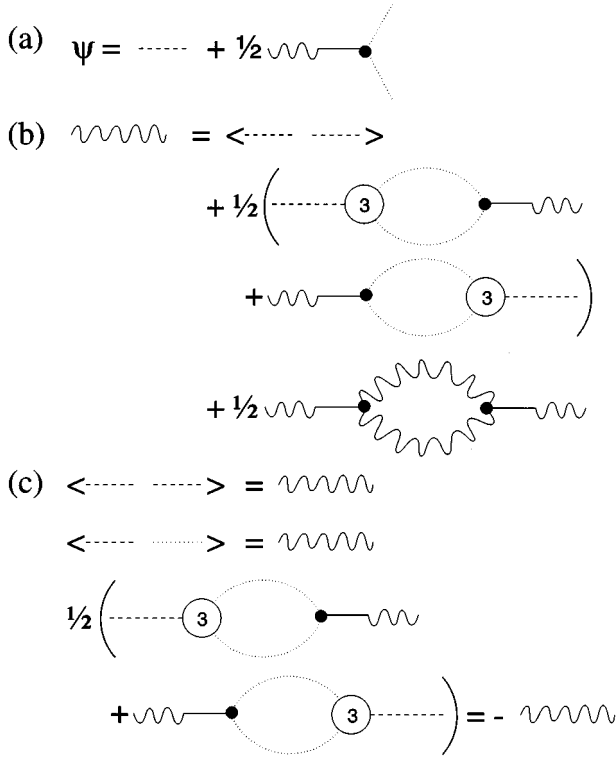

FIG. 9. (a) Diagrammatic representation of the decomposition $\psi = \psi_0 + R \frac{1}{2} M \Delta \xi \Delta \xi$ [Eq. (46a)] (in contrast to Fig. 6, the dotted line now stands for $\Delta \xi$); (b) associated covariance; (c) constraints through second order.

$$\langle \psi_0(1)(R \frac{1}{2} M \Delta \xi \Delta \xi)(1') \rangle + (1 \leftrightarrow 1') = -C(1, 1'), \quad (68)$$

where the right-hand side follows from the definition of the model [see discussion after Eq. (46b)], so that the last term of Eq. (66) evaluates to the right-hand side of the spectral balance equation (43a). It is typical of this kind of order-by-order constructive approach that constraints at a given order need not fully determine the cross correlations between ψ_0 and $\Delta \xi$. Thus Eq. (68) determines only a contraction (with M) of $\langle \psi_0 \Delta \xi \Delta \xi \rangle$. Later, I will argue that at fourth order one will require the more detailed condition

$$\langle \psi_0(1) \Delta \xi(2) \Delta \xi(3) \rangle = -\frac{1}{2} R(1; \bar{1}) M(\bar{1}, \bar{2}, \bar{3}) C(\bar{2}, 2) C(\bar{3}, 3); \quad (69)$$

see the discussion of Eq. (77). This satisfies Eq. (68) because of the spectral balance equation (43).

The argument thus far has not determined $\langle \psi_0 \Delta \xi \rangle$. Let us demand that

$$\langle \psi \Delta \xi \rangle = C. \quad (70)$$

Upon multiplying Eq. (46a) by $\Delta \xi$, averaging, and recalling that $\Delta \xi$ is Gaussian, one therefore obtains the constraint

$$\langle \psi_0 \Delta \xi \rangle = C. \quad (71)$$

As a check, the second-order realizability inequalities for ψ_0 and $\Delta \xi$ should be satisfied. These reduce to the statement

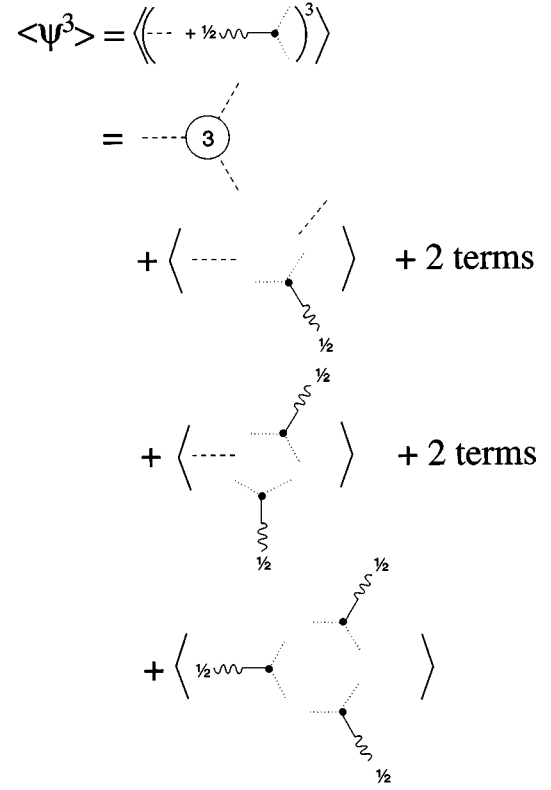

FIG. 10. Third-order cumulant of the decomposition (46): all possible graphs.

that the covariance matrix should be positive semidefinite. Explicitly, with the aid of Eqs. (67) and (71), one finds

$$\left\langle \begin{pmatrix} \psi_0 \\ \Delta \xi \end{pmatrix} (\psi_0 \ \Delta \xi) \right\rangle = \begin{pmatrix} \langle \psi_0^2 \rangle & \langle \psi_0 \Delta \xi \rangle \\ \langle \Delta \xi \psi_0 \rangle & \langle \Delta \xi^2 \rangle \end{pmatrix} \quad (72a)$$

$$= \begin{pmatrix} C & C \\ C & C \end{pmatrix}. \quad (72b)$$

Clearly the realizability inequality is marginally satisfied.

The constraints deduced so far are diagrammed in Fig. 9(c).

D. Third-order statistics

One can now proceed to third order. One has schematically

$$\langle \psi^3 \rangle = \langle \psi_0^3 \rangle + 3 \langle \psi_0^2 (R \frac{1}{2} M \Delta \xi \Delta \xi) \rangle + 3 \langle \psi_0 (R \frac{1}{2} M \Delta \xi \Delta \xi)^2 \rangle + \langle (R \frac{1}{2} M \Delta \xi \Delta \xi)^3 \rangle. \quad (73)$$

Let us choose

$$\langle \psi_0 \Delta \xi^4 \rangle = 0. \quad (74)$$

This turns out to be adequate for calculating statistics up to fourth order. Equation (73) is represented diagrammatically in Figs. 10 and 11. Those diagrams are to be compared with

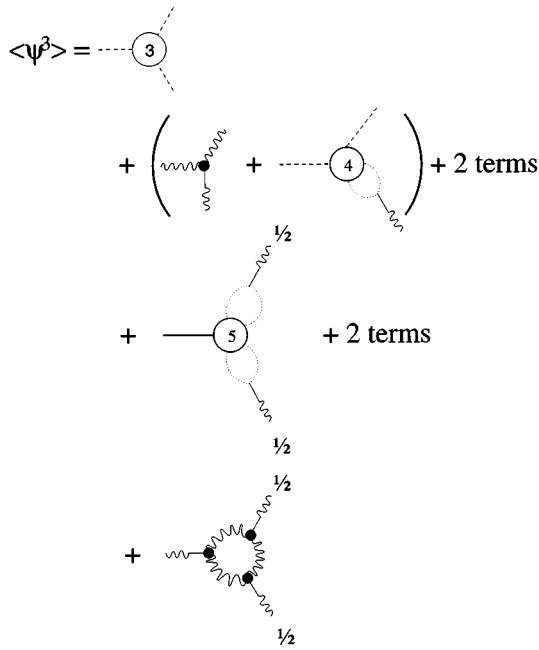

FIG. 11. Average of Fig. 10.

those of the DIA, which at third order read $G_3 = GGG\gamma$ or $\langle \psi\psi\psi \rangle = RMCC + (\text{two permutations})$ [Figs. 8 and 12(a)]. One can achieve agreement by choosing

$$\langle \psi_0^3 \rangle = -\langle (R\frac{1}{2}M\Delta\xi\Delta\xi)^3 \rangle \quad (75a)$$

and

$$\langle \langle \psi_0\psi_0\Delta\xi\Delta\xi \rangle \rangle = 0. \quad (75b)$$

The constraints deduced at this order are graphed in Fig. 12(b).

E. Fourth-order statistics

Finally, at fourth order one has

$$\begin{aligned} \langle \psi^4 \rangle &= \langle \psi_0^4 \rangle + 4\langle \psi_0^3 (R\frac{1}{2}M\Delta\xi\Delta\xi) \rangle + 6\langle \psi_0^2 (R\frac{1}{2}M\Delta\xi\Delta\xi)^2 \rangle \\ &+ 4\langle \psi_0 (R\frac{1}{2}M\Delta\xi\Delta\xi)^3 \rangle + \langle (R\frac{1}{2}M\Delta\xi\Delta\xi)^4 \rangle. \end{aligned} \quad (76)$$

Evaluation of the ensemble averages leads to a somewhat tedious proliferation of diagrams, representative ones of which are shown in Fig. 13. The first three terms of Fig. 13(a) are, of course, the Gaussian contributions to $\langle \psi^4 \rangle$. It can be verified that the remaining disconnected diagrams [an example is shown in Fig. 13(b)] sum to zero upon invoking Eq. (69) and the spectral balance equation (43). The class of (horizontally aligned) terms that can be bisected by a single vertical cut is obviously related to the desired result [Fig. 4(b)] for $\langle \langle \psi^4 \rangle \rangle_{\text{DIA}}$. Of those terms, the ones involving $\langle \psi_0\Delta\xi^3 \rangle$ [cf. Fig. 13(c)] will reproduce the first group of terms in Fig. 4(b) if

$$\begin{aligned} \langle \psi_0(1)\Delta\xi(2)M(3,4,5)\Delta\xi(4)\Delta\xi(5) \rangle \\ = C(1,4)C(2,5)M(3,4,5). \end{aligned} \quad (77)$$

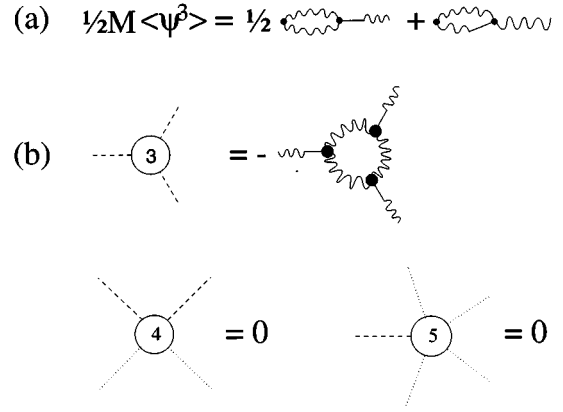

FIG. 12. (a) Contribution $\frac{1}{2}M\langle \psi^3 \rangle$ to the covariance equation; (b) a consistent choice of cumulants.

The remaining horizontal terms, involving $\langle \psi_0^2\Delta\xi \rangle$ [cf. Fig. 13(d)], reproduce the second group of terms in Fig. 4(b) if

$$\langle \psi_0(2)\psi_0(2)\Delta\xi(3) \rangle = C(1,\bar{1})C(2,\bar{2})M(\bar{1},\bar{2},\bar{3})R(3,\bar{3}). \quad (78)$$

[Recall the discussion of Eq. (69).]

Not shown in Fig. 13 are diagrams that stem from the original Langevin model with $\psi_0 = 0$. The freedom afforded

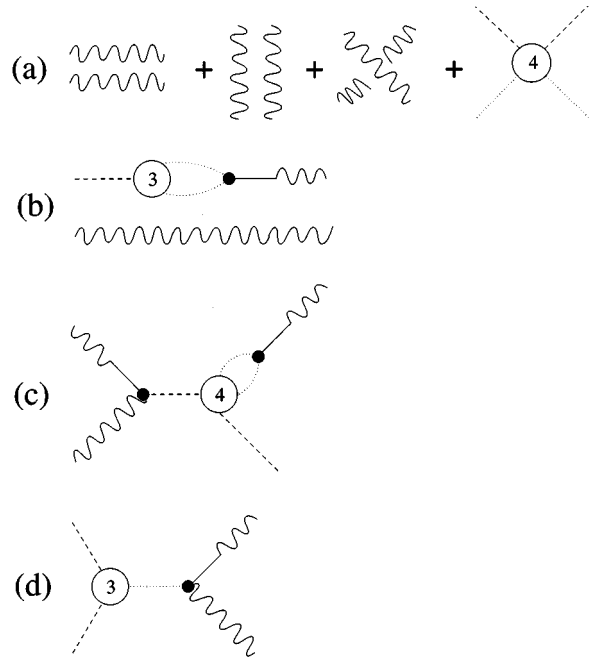

FIG. 13. Representative diagrams arising from the fourth-order average of the decomposition (46). (a) Expansion of $\langle \psi_0^4 \rangle$ into Gaussian and cumulant contributions; (b) example of a disconnected diagram; (c) typical term arising from $\langle \psi_0\Delta\xi^3 \rangle$; (d) typical term arising from $\langle \psi_0^2\Delta\xi \rangle$.

by the presence of ψ_0 is now crucial, as one can choose $\langle\langle\psi_0^4\rangle\rangle$ to cancel the unwanted terms. I do not present the details.

At this point, a variety of constraints on the cumulants of ψ_0 and $\Delta\xi$ have been deduced. In principle, it is necessary to verify that the relevant realizability inequalities are satisfied; this has not been done beyond second order. However, as remarked earlier, the freedom afforded by the addition of ψ_0 means that a construction of this type is guaranteed to exist, since the DIA is itself realizable through all orders due to the existence of the RCM.

This kind of construction guarantees that the linear Langevin equation augmented with an additive non-Gaussian correction will succeed in reproducing ψ statistics through fourth order. However, as discussed in Sec. III B 2, such a dynamically linear construction appears to be incapable of reproducing higher-order response functions such as $R(1;1',1'')$.

IV. MARKOVIAN APPROXIMATIONS TO Z_{DIA}

I now discuss approximate evaluations of Eq. (32). Computationally, the principal (and well-known) drawback of the DIA is the necessity of evaluating the time-history integrals. Various parametrizations of the two-time observables have been suggested; for a single field variable, one simple and frequently used one is

$$R_k(t;t') \approx H(t-t') \exp\left(-\int_{t'}^t d\bar{t} \eta_k(\bar{t})\right), \quad (79a)$$

$$C_k(t,t') \approx \hat{R}_k(t;t') C_k(t,t) \quad (t \geq t'). \quad (79b)$$

The latter approximation is the fluctuation-dissipation (FD) *Ansatz*, known to be exact in thermal equilibrium [38]. Markovian approximations to the equal-time statistics can be obtained by inserting these *Ansätze* into the DIA equations. However, a well-known [39] difficulty with this procedure is that the resulting equation for η_k need not be realizable. [This deficiency is related to the fact that, although the triad interaction time $\theta_{k,p,q}$ defined in the next paragraph (fully symmetric in \mathbf{k} , \mathbf{p} , and \mathbf{q}) appears correctly in the covariance equation, the asymmetric construction $(\eta_p + \eta_q)^{-1}$ appears in the equation for η_k .] Instead, it is better to generate the Markovian approximation from a Langevin amplitude equation, thereby ensuring realizability.

Kraichnan [40] showed that for single-field problems with Hermitian (real) linear damping ν_k , a realizable Markovian approximation to the second-order statistics can be generated from the Langevin equation [13]

$$\frac{\partial \psi_k}{\partial t} + \eta_k(t) \psi_k = \frac{1}{\sqrt{2}} w(t) \sum_{\Delta} M_{k,p,q} \sqrt{\text{Re} \theta_{k,p,q}(t)} \xi_p^*(t) \xi_q^*(t) \quad (80a)$$

$$\doteq f_k(t), \quad (80b)$$

where $w(t)$ is Gaussian white noise with unit strength, ξ is interpreted in the same way as in Eq. (41b), and $\theta_{k,p,q}$ is the triad interaction time

$$\theta_{k,p,q}(t) \doteq \int_0^t dt' \hat{R}_k(t;t') \hat{R}_p(t;t') \hat{R}_q(t;t') \quad (81a)$$

$$\begin{aligned} & \xrightarrow{t \rightarrow \infty} [\eta_k(\infty) + \eta_p(\infty) + \eta_q(\infty)]^{-1}. \end{aligned} \quad (81b)$$

Here

$$\eta_k \doteq \nu_k + \hat{\eta}_k, \quad (82)$$

$\hat{\eta}_k$ being nonlinear damping that is specified in Eq. (87) below. In Eq. (80a), the Re operator is superfluous because of the restriction to Hermitian linear damping. I retain complex θ in order to define a natural [although problematic; see the paragraph after Eq. (87)] generalization.

In order to determine an $\hat{\eta}_k$ compatible with Eq. (80a), note that one has

$$\langle f_k(t) f_k^*(t') \rangle = 2F_k(t) \delta(t-t'), \quad (83)$$

where

$$F_k(t) \doteq \frac{1}{2} \sum_{\Delta} |M_{k,p,q}|^2 \text{Re} \theta_{k,p,q} C_p(t) C_q(t). \quad (84)$$

Thus

$$\langle f_k(t) \psi_k^*(t') \rangle = \int_{-\infty}^{t'} d\bar{t} \langle f_k(t) \hat{R}_k(t';\bar{t}) f_k^*(\bar{t}) \rangle \quad (85a)$$

$$= \begin{cases} 0 & (t > t') \\ F_k(t) & (t = t'). \end{cases} \quad (85b)$$

The $t > t'$ part of this result guarantees that a fluctuation-dissipation relation holds. The $t = t'$ result leads to the spectral evolution equation

$$\frac{\partial}{\partial t} C_k + 2(\text{Re} \eta_k) C_k = 2F_k, \quad (86)$$

from which it follows that quadratic invariants of the primitive equation are conserved by the nonlinear terms if

$$\hat{\eta}_k = - \sum_{\Delta} M_{k,p,q} M_{p,q,k}^* \theta_{k,p,q}^* C_q(t). \quad (87)$$

Equations (87), (84), and (86) define the so-called ‘‘DIA-based EDQNM’’ approximation [41,42], henceforth called simply EDQNM (where EDQNM stands for eddy-damped quasnormal Markovian). Bowman [41] has reviewed the history of this approximation in detail.

In the presence of linear waves ($\text{Im} \nu_k \neq 0$), Bowman [41,42] demonstrated that the transient evolution described by the EDQNM is nonrealizable, possibly precluding the achievement of a realizable steady state. He showed that a realizable Markovian closure (RMC) can be developed if a particular symmetrical form of the fluctuation-dissipation relation is employed. The RMC is constructed to approach asymptotically the steady-state spectral intensities of the EDQNM. Predictions of the RMC have been compared successfully to direct numerical simulations of three-wave models [41,42], Hasegawa-Mima [10] dynamics [43,44], and

Hasegawa-Wakatani [11] dynamics [45,46]. The resulting η 's and C_k 's can be used in conjunction with Eq. (79b) to estimate Z^c according to Eq. (36).

The formula for the Markovian approximation to the steady-state Z^c can be derived in two ways: (i) by inserting the form (79b) directly into Eq. (36) and evaluating the resulting integrals and (ii) by noting that the Langevin equation (80b) follows from representation (41b) when the M of the latter is replaced by

$$M \rightarrow \sqrt{2\theta w} M. \quad (88)$$

The two derivations are almost identical. I restrict my attention to single-field problems. Considering first procedure (i), I introduce the variables $\tau \doteq t - t'$ and $\bar{\tau} \doteq t - \bar{t}'$ and write the steady-state form of Eq. (36) as

$$Z_{\text{DIA},k}^{c(1)} = 4 \sum_{p,q} \sum_{\bar{p},\bar{q}} \{ d_{k,p,q} d_{k,\bar{p},\bar{q}}^* I_1(\mathbf{k}; \mathbf{p}, \mathbf{q}; \bar{\mathbf{p}}, \bar{\mathbf{q}}) + [d_{k,p,q} c_{k,\bar{p},\bar{q}}^* I_2^*(\mathbf{k}; \bar{\mathbf{p}}, \bar{\mathbf{q}}; \mathbf{p}, \mathbf{q})]^H \}, \quad (89)$$

where

$$I_1(\mathbf{k}; \mathbf{p}, \mathbf{q}; \bar{\mathbf{p}}, \bar{\mathbf{q}}) \doteq \int_0^\infty d\tau \int_0^\infty d\bar{\tau} \hat{R}_p(\tau) C_q(\tau) \times C_k(\tau - \bar{\tau}) \hat{R}_{\bar{p}}^*(\bar{\tau}) C_{\bar{q}}^*(\bar{\tau}), \quad (90a)$$

$$I_2(\mathbf{k}; \mathbf{p}, \mathbf{q}; \bar{\mathbf{p}}, \bar{\mathbf{q}}) \doteq \int_0^\infty d\tau \int_0^\tau d\bar{\tau} C_p(\tau) C_q(\tau) \times \hat{R}_k(\tau - \bar{\tau}) \hat{R}_{\bar{p}}^*(\bar{\tau}) C_{\bar{q}}^*(\bar{\tau}). \quad (90b)$$

Upon introducing the FD Ansatz, one finds

$$I_2(\mathbf{k}; \mathbf{p}, \mathbf{q}; \bar{\mathbf{p}}, \bar{\mathbf{q}}) = C_q C_p C_{\bar{q}} \hat{I}_2(\mathbf{k}; \mathbf{p}, \mathbf{q}; \bar{\mathbf{p}}, \bar{\mathbf{q}}), \quad (91)$$

where $C_p \equiv C_p(\tau=0)$ is the steady-state intensity and

$$\hat{I}_2(\mathbf{k}; \mathbf{p}, \mathbf{q}; \bar{\mathbf{p}}, \bar{\mathbf{q}}) \doteq \int_0^\infty d\tau \int_0^\tau d\bar{\tau} \hat{R}_p(\tau) \hat{R}_q(\tau) \times \hat{R}_k(\tau - \bar{\tau}) \hat{R}_{\bar{p}}^*(\bar{\tau}) \hat{R}_{\bar{q}}^*(\bar{\tau}). \quad (92)$$

Upon writing $\int_0^\infty d\bar{\tau} = \int_0^\tau d\bar{\tau} + \int_\tau^\infty d\bar{\tau}$ and reversing the order of integration in the second term, one also finds

$$I_1(\mathbf{k}; \mathbf{p}, \mathbf{q}; \bar{\mathbf{p}}, \bar{\mathbf{q}}) = C_q C_k C_{\bar{q}} [\hat{I}_2(\mathbf{k}; \mathbf{p}, \mathbf{q}; \bar{\mathbf{p}}, \bar{\mathbf{q}}) + \hat{I}_2^*(\mathbf{k}; \bar{\mathbf{p}}, \bar{\mathbf{q}}; \mathbf{p}, \mathbf{q})]. \quad (93)$$

Then

$$Z_{\text{DIA},k}^{c(1)} = 4 \sum_{p,q} \sum_{\bar{p},\bar{q}} C_q C_{\bar{q}} \text{Re}[(2d_{k,p,q} d_{k,\bar{p},\bar{q}}^* C_k + d_{k,p,q} c_{k,\bar{p},\bar{q}}^* C_{\bar{p}}) \hat{I}_2(\mathbf{k}; \mathbf{p}, \mathbf{q}; \bar{\mathbf{p}}, \bar{\mathbf{q}})]. \quad (94)$$

This formula holds for any steady-state DIA solution with a FD relation. For the specific parametrization $\hat{R}_k(\tau) = \exp(-\eta_k \tau)$, one readily finds

$$\hat{I}_2(\mathbf{k}; \mathbf{p}, \mathbf{q}; \bar{\mathbf{p}}, \bar{\mathbf{q}}) = \theta_{k,p,q} / \Delta \eta, \quad (95)$$

where

$$\Delta \eta \doteq \eta_p + \eta_q + \eta_{\bar{p}}^* + \eta_{\bar{q}}^*. \quad (96)$$

Formula (94) will be evaluated for a special solvable model in Sec. V.

Turning now to procedure (ii), the modification (88) of the bare vertex function (mode-coupling coefficient) can be used to define a Markovian Langevin model for higher-order statistics in the same way as in Sec. III. If one does so, the diagrammatic analysis of Sec. III goes through unchanged [with the new interpretation (88) for the vertices]; one is led to a formula like (36), except that extra factors of $\sqrt{2\theta w}$ appear inside the time integrals (one evaluated at t' , one at \bar{t}') and the average over the white noise must be performed. That average produces the factor $\delta(\bar{t} - \bar{t}') = \delta(\tau - \bar{\tau})$. What results for the steady state is

$$Z_{\text{DIA},k}^{c(2)} = 4 \sum_{p,q} \sum_{\bar{p},\bar{q}} 2 \sqrt{\theta_{k,p,q}} \sqrt{\theta_{k,\bar{p},\bar{q}}} \{ d_{k,p,q} d_{k,\bar{p},\bar{q}}^* I_1'(\mathbf{k}; \mathbf{p}, \mathbf{q}; \bar{\mathbf{p}}, \bar{\mathbf{q}}) + [d_{k,p,q} c_{k,\bar{p},\bar{q}}^* I_2'(\mathbf{k}; \bar{\mathbf{p}}, \bar{\mathbf{q}}; \mathbf{p}, \mathbf{q})]^H \}, \quad (97)$$

where I_i' are the integrals I_i with the terms with argument $\tau - \bar{\tau}$ replaced by a delta function of that argument. One readily finds

$$\hat{I}_1' = \Delta \eta^{-1}, \quad \hat{I}_2' = (2\Delta \eta)^{-1} \quad (98)$$

(the factor of 1/2 in \hat{I}_2' arises from integrating the delta function over half of its support). This leads to a formula that is identical to (89) with Eqs. (91) and (95), except that $\theta_{k,p,q}$ is replaced by $\sqrt{\theta_{k,p,q}} \sqrt{\theta_{k,\bar{p},\bar{q}}}$. The formulas are identical when only a single triad interaction time is relevant, as in the three-mode model discussed in Sec. V.

For problems with multiple coupled fields, the derivation of realizable Markovian closures is more intricate. The difficulties and various remedies are described in detail by Bowman [41] and Bowman *et al.* [42].

V. FOURTH-ORDER STATISTICS FOR SYSTEMS OF THREE COUPLED MODES

The study of simple nonlinear models that nevertheless retain the essence of the statistical closure problem has been very profitable [5,2]. Kraichnan [15] considered a simple system of three coupled modes in order to compare the performance of the DIA (for second-order statistics) with exact ensemble-averaged solutions of the equations of motion. Krommes [47] extended that work to include linear forcing and damping; see also Ref. [42]. Kraichnan also discussed a degenerate case of the three-mode problem that could be fully solved analytically, both for the exact equations and for the DIA. Further results on that solvable case were given by Bowman *et al.* [41,42]. Chen *et al.* discussed the prediction of Z_{DIA} for the mean-square nonlinearity.

Here, I briefly consider for pedagogical purposes a slight variant of Kraichnan's solvable three-mode model that provides a simple example of the development of non-Gaussian kurtosis from Gaussian initial conditions and allows an illustrative test of the DIA and Markovian formulas for Z^c . The fundamental equation of motion for three fields labeled by K , P , and Q is taken to be

$$\dot{\psi}_K = M_K \psi_P^* \psi_Q^*, \quad (99)$$

with two similar equations for the cyclic permutations $K \rightarrow P \rightarrow Q \rightarrow K$. [Equation (99) is compatible with the fundamental mode-coupling convention (40), with $M_{K,p,q} = M_K(\delta_{p,P}\delta_{q,Q} + \delta_{p,Q}\delta_{q,P})$.] In order that the ψ_k behave like the Fourier amplitudes of a real field $\psi(x)$, the complex conjugates of the above equations must also be considered. (See the related discussion in Ref. [18].) One readily verifies that those are compatible with the reality condition $\psi_k^* = \psi_{-k}$. Thus one actually considers the set of modes $k = \{K, P, Q, -K, -P, -Q\}$.

Given the Fourier interpretation of the ψ_k 's, a natural statistic to consider is $Z \doteq \langle \psi(x)^4 \rangle \equiv \langle \psi^4 \rangle$; the associated kurtosis is $\bar{Z}^c \doteq \langle \psi^4 \rangle / \langle \psi^2 \rangle^2 - 3$. The detailed evaluation of $\langle \psi^4 \rangle$ in terms of Fourier amplitudes is presented in the Appendix; see Eq. (A11).

The solvable special case is defined [15] by $M_K = 1$, $M_P = -1$, $M_Q = 0$, and Gaussian initial conditions [applied independently to the real and imaginary parts of $\psi_k(0)$] such that $C_K(0) = 2$, $C_P(0) = 0$, and $C_Q(0) = 1$. Therefore, mode Q does not evolve and ψ_Q serves as a Gaussianly distributed random frequency of a linear oscillator in which ψ_K and ψ_P play the role of coordinate and momentum. Kraichnan provided the analytical solution for the second-order statistics of both the exact dynamics and the DIA; Bowman [41,42] found solutions for both the EDQNM closure and the RMC [41,42]. For all of those, the asymptotic energies are $C_K(\infty) = C_P(\infty) = C_Q(\infty) = 1$ [$C_Q(t) \equiv 1$] and a FD relation holds. One finds (see the Appendix) that the exact kurtosis evolves from its initial Gaussian value of 0 to an asymptotic value of $\bar{Z}^c = 1/3$.

It is straightforward to evaluate Eq. (94). It contains a factor

$$2d_{k,\bar{p},\bar{q}} + c_{k,\bar{p},\bar{q}} = 2M_{\bar{p}} + M_k \quad (100a)$$

$$= (M_{\bar{p}} - M_{\bar{q}}) + (M_{\bar{p}} + M_{\bar{q}} + M_k). \quad (100b)$$

The last term vanishes by definition of the mode-coupling coefficients for the model; the antisymmetry of $M_{\bar{p}} - M_{\bar{q}}$ then leads to $Z_k^c \equiv 0$ for the steady states of both the DIA and the (DIA-based) EDQNM. That the DIA-based approximations predict no non-Gaussian correction even for such a simple model is a further illustration of the result of Chen *et al.* that Z_{DIA} is inadequate as a general prediction of non-Gaussian statistics.

VI. DISCUSSION

This work is intended to unify a variety of approaches to the calculation of various non-Gaussian statistics of nonlinear systems. The principal formula, Eq. (36), generalizes to

inhomogeneous situations the result of Chen *et al.* [4] for the DIA to the general fourth-order statistic Z defined by Eq. (2a). I showed how Z_{DIA} follows naturally from the MSR formalism for the statistical dynamics of classical fields. I emphasized that the original Langevin representation of the DIA due to Leith and Kraichnan is valid only through second order. (This point was no doubt well understood by those authors, but it is worth reiterating to a more general audience.) I argued that the modified Langevin representation (46) could be specified in such a way that pure ψ statistics could be reproduced up to and including a chosen order. The important conceptual point was the extra freedom introduced by the addition of an additive non-Gaussian correction ψ_0 to the original product form of the noise. I sketched the calculation of the third- and fourth-order constraints linking the two independent fields ψ_0 and $\Delta\xi$. Finally, I derived a Markovian representation for Z_{DIA} and illustrated its use with a simple solvable three-mode model.

In conclusion, I emphasize the points made in the first several paragraphs of Sec. I. The extent to which moment-closure-based approaches to higher-order statistics are useful for models of nonlinear systems with low degrees of symmetry (typical of fusion-plasma applications, for example) remains to be seen. Certainly the results of Chen *et al.* [4] and of Sec. V show definitively that they are not adequate in general. The development of better yet workable PDF-based approximations presents an important challenge for the future [8].

ACKNOWLEDGMENTS

This work was supported in part by U.S. Department of Energy Contract No. DE-AC02-76-CHO-3073 and in part by the National Science Foundation Grant No. PHY94-07194. I am pleased to acknowledge the gracious hospitality and outstanding scientific ambience of the Institute for Theoretical Physics, University of California, Santa Barbara, California, at which some of the work was performed. I am very grateful to Dr. M. Golub-Smith for many stimulating discussions and to Dr. M. Ottaviani for carefully reading the manuscript and offering useful suggestions.

APPENDIX: EVALUATION OF $\langle \psi^4 \rangle$ FOR SYSTEMS OF THREE COUPLED MODES

The derivation of formula (A11) for $\langle \psi^4 \rangle$ in terms of Fourier amplitudes involves a few subtleties, particularly in the context of three-mode dynamics. I therefore present the discussion in some detail.

It is useful to first review the straightforward evaluation of $\langle \psi^2 \rangle$. One way of writing the convolution theorem for fields real in x space is

$$[\psi^2(x)]_k = \sum_{p,q} \delta_{k+p+q} \psi_p^* \psi_q^*. \quad (A1)$$

For spatially homogeneous statistics, the ensemble average may be supplemented or replaced by the spatial integral $L^{-1} \int dx$, which selects the $k=0$ component:

$$\langle \psi^2(x) \rangle = \langle [\psi^2]_{k=0} \rangle = \sum_p \langle |\psi_p|^2 \rangle = \sum_p C_p. \quad (\text{A2})$$

Here the sums are over both positive and negative values of p . ($p=0$ does not contribute because it is assumed that $\langle \psi \rangle = \psi_{p=0} = 0$.) For later use, one has also

$$\langle \psi^2 \rangle^2 = \sum_p \sum_{p'} C_p C_{p'} \quad (\text{A3a})$$

$$= 2 \sum_p C_p^2 + \sum_p \sum_{p' \neq \{p, -p\}} C_p C_{p'} \quad (\text{A3b})$$

$$= 4 \left(\sum_{p>0} C_p^2 + \underbrace{\sum_{p>0} \sum_{p'>0}_{p' \neq p} C_p C_{p'}} \right). \quad (\text{A3c})$$

To evaluate $\langle \psi(x)^4 \rangle$, one may write

$$\langle \psi^4 \rangle = \langle (\psi^2)^2 \rangle \quad (\text{A4a})$$

$$= \sum_k \langle (\psi^2)_k (\psi^2)_k^* \rangle \quad (\text{A4b})$$

$$= \sum_k \sum_{p,q} \sum_{p',q'} \delta_{k+p+q} \delta_{k+p'+q'} \langle \psi_p^* \psi_q^* \psi_{p'} \psi_{q'} \rangle. \quad (\text{A4c})$$

Now focus particularly on the three-mode problem defined in Sec. V. One must recognize that although the sums in Eq. (104c) over p , q , p' , and q' contain no zero component, there is a $k=0$ term [cf. Eq. (A2)]. Furthermore, other k 's

not included in the dynamically active spectrum contribute to $\langle \psi^4 \rangle$. For example, if one thinks of K , P , and Q as vectors rather than just mode indices, then the fundamental dynamical triads are $K+P+Q=0$ and $(-K)+(-P)+(-Q)=0$. Although such sums as $K-P+Q$ do not vanish, beats such as $k=P-Q$ can contribute to $\langle \psi^4 \rangle$. That is, the k summation in Eq. (A4c) is unrestricted, so it may be performed in the conventional way:

$$\langle \psi^4 \rangle = \sum_{p,q} \sum_{p',q'} \delta_{p+q,p'+q'} \langle \psi_p^* \psi_q^* \psi_{p'} \psi_{q'} \rangle. \quad (\text{A5})$$

One may now systematically decompose the four sums into all distinct possibilities. Since

$$\sum_{p,q} = \sum_{\substack{p,q \\ p+q=0}} + \sum_{\substack{p,q \\ p+q \neq 0}}, \quad (\text{A6})$$

one finds

$$\langle \psi^4 \rangle = \sum_p \sum_{p'} \langle |\psi_p|^2 |\psi_{p'}|^2 \rangle + Q, \quad (\text{A7})$$

where

$$Q \doteq \sum_{\substack{p,q \\ p+q \neq 0}} \sum_{\substack{p',q' \\ p'+q' \neq 0}} \delta_{p+q,p'+q'} \langle \psi_p^* \psi_q^* \psi_{p'} \psi_{q'} \rangle. \quad (\text{A8})$$

Upon separating off the terms with $p' = \{p, -q\}$, one finds

$$\langle \psi^4 \rangle = 2 \sum_p \langle |\psi_p|^4 \rangle + \sum_p \sum_{p' \neq \{p, -p\}} \langle |\psi_p|^2 |\psi_{p'}|^2 \rangle + Q, \quad (\text{A9})$$

where

$$\begin{aligned} Q &= \sum_p \sum_{p'} \delta_{2p,2p'} \langle \psi_p^* \psi_p^* \psi_{p'} \psi_{p'} \rangle + \underbrace{\sum_p \sum_{q \neq p} \delta_{p+q,2p'} \sum_{p'} \langle \psi_p^* \psi_q^* \psi_{p'} \psi_{p'} \rangle}_{p+q \neq 0} \\ &+ \underbrace{\sum_p \sum_{p'} \sum_{q' \neq p'} \delta_{2p,p'+q'} \langle \psi_p^* \psi_p^* \psi_{p'} \psi_{q'} \rangle}_{p'+q' \neq 0} + \underbrace{\sum_p \sum_{q \neq p} \sum_{p'} \sum_{q' \neq p'} \delta_{p+q,p'+q'} \langle \psi_p^* \psi_q^* \psi_{p'} \psi_{q'} \rangle}_{p+q \neq 0, p'+q' \neq 0} \end{aligned} \quad (\text{A10a})$$

$$\begin{aligned} &= \sum_p \langle |\psi_p|^4 \rangle + \underbrace{\sum_p \sum_{q \neq p} \sum_{p'} \delta_{p+q,2p'} \langle \psi_p^* \psi_q^* \psi_{p'} \psi_{q'} \rangle}_{p+q \neq 0} + \underbrace{\sum_p \sum_{p'} \sum_{q' \neq p'} \delta_{2p,p'+q'} \langle \psi_p^* \psi_p^* \psi_{p'} \psi_{q'} \rangle}_{p'+q' \neq 0} \\ &+ \sum_p \sum_{q \neq \{p, -p\}} \langle |\psi_p|^2 |\psi_q|^2 \rangle + \sum_p \sum_{q \neq \{p, -p\}} \langle |\psi_p|^2 |\psi_q|^2 \rangle + \sum_p \sum_{q \neq \{p, -p\}} \sum_{p' \neq \{p, q\}} \sum_{q' \neq \{q, p, p'\}} \langle \psi_p^* \psi_q^* \psi_{p'} \psi_{q'} \rangle. \end{aligned} \quad (\text{A10b})$$

The underlined terms vanish for homogeneous statistics and one is left with

$$\langle \psi^4 \rangle = 3 \left(\sum_p \langle |\psi_p|^4 \rangle + \sum_p \sum_{p' \neq \{p, -p\}} \langle |\psi_p|^2 |\psi_{p'}|^2 \rangle \right). \quad (\text{A11})$$

Because for Gaussian statistics $\langle |\psi_p|^4 \rangle = 2C_p^2$ and $\langle |\psi_p|^2 |\psi_{p'}|^2 \rangle = C_p C_{p'}$ (for $p' \neq p$), one verifies that formulas (A11) and (A3b) are compatible with the Gaussian result $\bar{Z}^c = 0$.

For the solvable model described in Sec. V, it can be readily verified that

$$\psi_K = A \cos(|\Omega|t), \quad (\text{A12a})$$

$$\psi_P = - \left(\frac{\Omega^*}{|\Omega|} \right) A^* \sin(|\Omega|t), \quad (\text{A12b})$$

$$\psi_Q = \Omega, \quad (\text{A12c})$$

where A and Ω are (complex) Gaussian random variables with $\langle |A|^2 \rangle = 2$, $\langle |\Omega|^2 \rangle = 1$. With $\Omega = w \exp(i\varphi)$, expectations can be computed with the PDF $P(w, \varphi) = \pi^{-1} w \exp(-w^2)$. Although analytic forms for all t can be found, it is sufficient here to calculate the long-time limits (with the aid of the Riemann-Lebesgue phase-mixing lemma)

$$C_K = C_P = C_Q = 1, \quad (\text{A13a})$$

$$\langle |\psi_K|^4 \rangle = \langle |\psi_P|^4 \rangle = 3, \quad \langle |\psi_Q|^4 \rangle = 2, \quad (\text{A13b})$$

$$\langle |\psi_K|^2 |\psi_P|^2 \rangle = \langle |\psi_P|^2 |\psi_Q|^2 \rangle = \langle |\psi_Q|^2 |\psi_K|^2 \rangle = 1. \quad (\text{A13c})$$

Upon inserting these values into Eqs. (A2) and (A11), one finds $\langle \psi^2 \rangle = 6$, $\langle \psi^4 \rangle = 120$, or

$$\bar{Z}^c = 1/3. \quad (\text{A14})$$

The deviation from the Gaussian value $\bar{Z}^c = 0$ arises here from the non-Gaussian values of $\langle |\psi_K|^4 \rangle$ and $\langle |\psi_P|^4 \rangle$ (3 rather than 2).

-
- [1] P. C. Martin, E. D. Siggia, and H. A. Rose, *Phys. Rev. A* **8**, 423 (1973).
- [2] J. A. Krommes, in *Handbook of Plasma Physics*, edited by A. A. Galeev and R. N. Sudan (North-Holland, Amsterdam, 1984), Vol. 2, Chap. 5.5, p. 183.
- [3] R. H. Kraichnan, *Proc. Symp. Appl. Math* **13**, 199 (1962).
- [4] H. Chen, J. R. Herring, R. M. Kerr, and R. H. Kraichnan, *Phys. Fluids A* **1**, 1844 (1989).
- [5] R. H. Kraichnan, *J. Math. Phys.* **2**, 124 (1961).
- [6] R. H. Kraichnan, *J. Fluid Mech.* **5**, 497 (1959).
- [7] H.-D. Chen, S. Chen, and R. H. Kraichnan, *Phys. Rev. Lett.* **63**, 2657 (1989).
- [8] R. H. Kraichnan, in *New Perspectives in Turbulence*, edited by L. Sirovich (Springer, New York, 1991), Chap. 1, p. 1.
- [9] R. H. Kraichnan, *Phys. Rev. Lett.* **65**, 575 (1990).
- [10] A. Hasegawa and K. Mima, *Phys. Fluids* **12**, 87 (1978).
- [11] A. Hasegawa and M. Wakatani, *Phys. Rev. Lett.* **50**, 682 (1983).
- [12] J. A. Krommes, *Theoretical and Computational Plasma Physics* (International Atomic Energy Agency, Vienna, 1978), p. 405.
- [13] C. E. Leith, *J. Atmos. Sci. U.S.A.* **28**, 145 (1971).
- [14] R. H. Kraichnan, *J. Fluid Mech.* **41**, 189 (1970).
- [15] R. H. Kraichnan, *Phys. Fluids* **6**, 1603 (1963).
- [16] R. Kubo, *J. Phys. Soc. Jpn.* **17**, 1100 (1962).
- [17] J. Schwinger, *Proc. Natl. Acad. Sci. U.S.A.* **37**, 452 (1951).
- [18] H. A. Rose, Ph.D. thesis, Harvard University, 1974 (unpublished).
- [19] R. V. Jensen, *J. Stat. Phys.* **25**, 183 (1981).
- [20] H. K. Janssen, *Z. Phys. B* **23**, 377 (1976).
- [21] C. DeDominicis, *J. Phys. (Paris) Colloq.* **1**, 247 (1976).
- [22] R. Phythian, *J. Phys. A* **10**, 777 (1977).
- [23] U. Dekker and F. Haake, *Phys. Rev. A* **11**, 2043 (1975).
- [24] The sign convention used here differs from the conventional one employed by MSR. It is chosen so that the form of the Dyson equation for the infinitesimal response function is

- $\partial_t R + \dots + \Sigma R = \delta(t-t')$, heuristically suggesting that the role of Σ is to provide a nonlinear damping and a resonance broadening.
- [25] There is no suggestion here that such power-series expansion is adequate, in general. The first vertex renormalization is well behaved [5,2], but little is known about the Γ expansion beyond first order. Kraichnan [*Phys. Fluids* **7**, 1723 (1964)] has stressed that random Galilean invariance is violated by any order of such Eulerian expansions and has introduced successful Lagrangian alternatives [*Phys. Fluids* **8**, 575 (1965)]. Krommes (Ref. [2], p. 229) has suggested an alternative truncation procedure that differs from the Γ expansion beyond first order, but little is known about that (continued-fraction-like) scheme either and it is almost certainly impractical to implement for realistic physical problems. A promising technique for incorporating vortex corrections is described by Kraichnan [in *Theoretical Approaches to Turbulence*, edited by D. L. Dwoyer, M. Y. Hussaini, and R. G. Voight (Springer, New York, 1985), p. 91] in the form of his decimation scheme.
- [26] There is a somewhat subtle point here. Equation (31) [the last term of Eq. (30)] is not fully symmetric in its arguments, although $G_4(1,2,3,4)$ is. This apparent contradiction is resolved by noting that when defining a statistic such as Z , a contraction is invariably made [cf. Eq. (2b)] that separates the four arguments into two pairs. In Eq. (30), the pairs are (1,2) and (3,4) [cf. the first term on the right-hand side of Eq. (30)]. This amounts to assigning a horizontal orientation to the graphs, with points (1,2) to the left and (3,4) to the right. One should more properly use a notation such as $G_{4,\text{DIA}}(1,2;3,4)$, where the semicolon distinguishes the selected pairs. Although in the text a possibly ambiguous notation is used in which arguments are not written explicitly, the situation is quite clear graphically.
- [27] Another way of obtaining information about fourth-order statistics would be to functionally differentiate Eq. (23) with respect to $\gamma(1,2)$. However, this procedure merely reproduces

- the Bethe-Salpeter equation; see Ref. [2], Eqs. (218)–(226).
- [28] J. C. Collins, *Renormalization* (Cambridge University Press, Cambridge, 1984).
- [29] The basic interpretation is given most clearly by Kraichnan [Phys. Fluids **6**, 1603 (1963)]. Additional discussion describing analogs between these terms and collision operators familiar in plasma physics was given by Krommes and Kotschenreuther [J. Plasma Phys. **27**, 83 (1982)].
- [30] P. Similon, Ph.D. thesis, Princeton University, 1981 (unpublished).
- [31] R. H. Kraichnan, in *Nonlinear Dynamics*, edited by R. H. G. Helleman (New York Academy of Sciences, New York, 1980), p. 37.
- [32] R. H. Kraichnan, in *Second Symposium on Naval Hydrodynamics* (Office of Naval Research, Arlington, VA, 1958), p. 29.
- [33] J. R. Herring and R. H. Kraichnan, in *Statistical Models and Turbulence*, edited by M. Rosenblatt and C. van Atta (Springer, New York, 1972), p. 148.
- [34] On the other hand, the higher-order statistics predicted by the original Langevin model *are* realizable. Of course, there is no guarantee that any particular realizable closure—either the DIA or another—accurately represents the physics.
- [35] R. Phythian, J. Phys. A **9**, 269 (1976).
- [36] U. Deker, Phys. Rev. A **19**, 846 (1979).
- [37] H. A. Rose, Physica D **14**, 216 (1985).
- [38] R. H. Kraichnan, Phys. Rev. **113**, 1181 (1959).
- [39] D. C. Leslie, *Developments in the Theory of Turbulence* (Clarendon, Oxford, 1973).
- [40] R. H. Kraichnan, J. Fluid Mech. **47**, 513 (1971).
- [41] J. Bowman, Ph.D. thesis, Princeton University, 1992 (unpublished).
- [42] J. Bowman, J. A. Krommes, and M. Ottaviani, Phys. Fluids B **5**, 3558 (1993).
- [43] M. Ottaviani, J. C. Bowman, and J. A. Krommes, Phys. Fluids B **3**, 2186 (1991).
- [44] J. C. Bowman and J. A. Krommes, Phys. Plasmas (to be published).
- [45] G. Hu, Ph.D. thesis, Princeton University, 1995 (unpublished).
- [46] G. Hu, J. A. Krommes, and J. C. Bowman, Phys. Lett. A **202**, 117 (1994).
- [47] J. A. Krommes, Phys. Fluids **25**, 1393 (1982).